

Shop Tip Piston Installation

Caution: Do not install piston pin without lubricating it first with motor oil or assembly lube. Touch up outer edges of piston pins with emery cloth before installation.

1. Refer to applicable service manual for proper installation methods.
2. Piston should be measured front-to-rear at the base of piston skirt, perpendicular to wrist pin.
3. Piston should be set-up with the following tolerances:

Recommended piston/cylinder running clearances:

	Minimum	Maximum	Preferred
Evolution) Models (Aluminum Cylinders)	.0015	.0022	.002
Big Twin Models (Cast Iron Cylinders)	.0015	.003	.0025
Sportster Models (Cast Iron Cylinders)	.003	.004	.0035

Specifications for ring end-gap are supplied with the ring sets and vary by type and size.

Note: Run engine at moderate speeds for at least 500 miles, avoiding excessive running in lower gears, in order to properly break-in new pistons and rings.

1,000 CC SPORTSTER CYLINDER IDENTIFICATION CHART

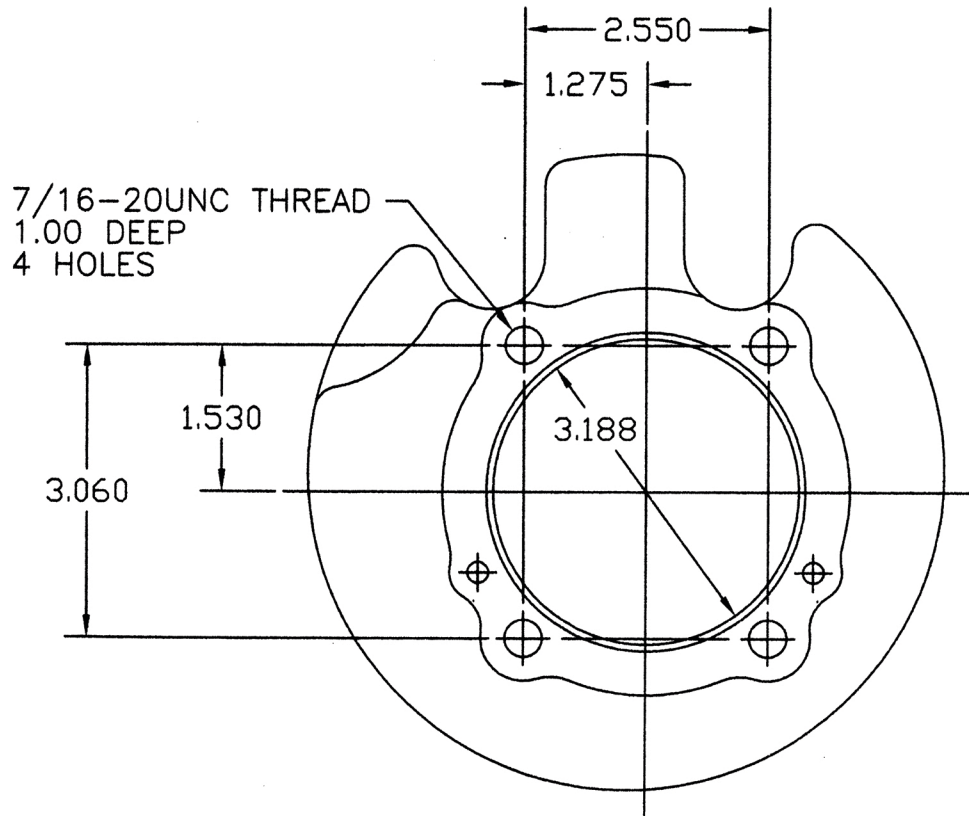

XL CYLINDER TOP
1,000 CC
1972
VT 11-0488 FRONT
VT 11-0489 REAR

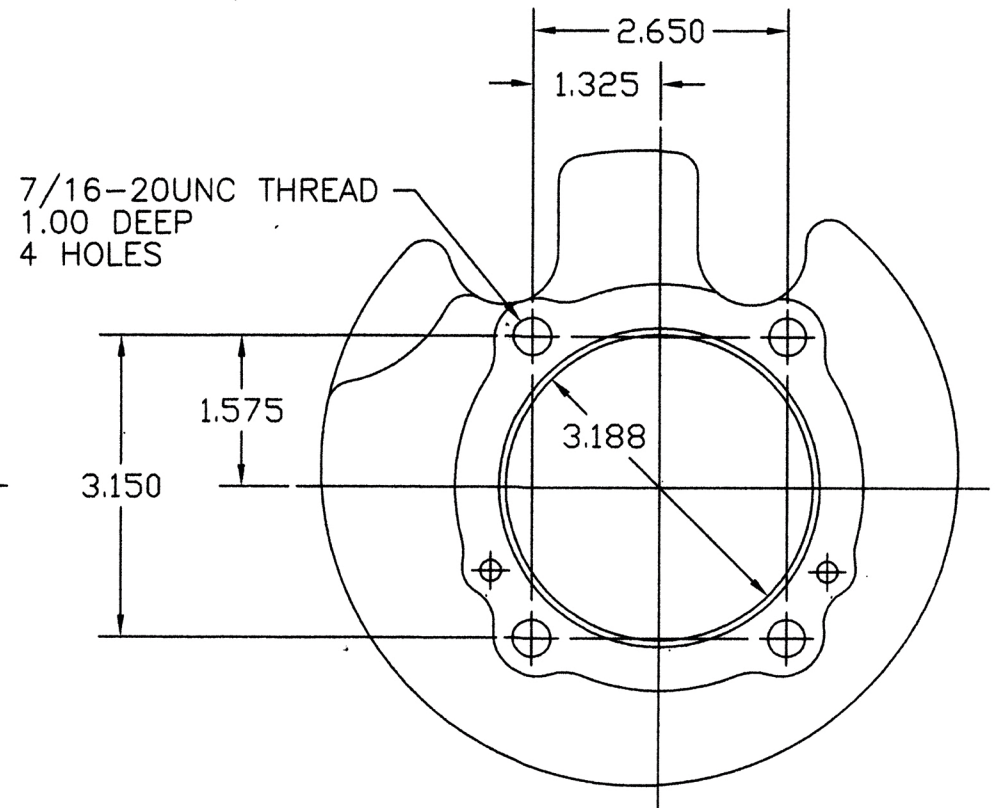

XL CYLINDER TOP
1,000 CC
1973-1985
VT 11-0504 FRONT
VT 11-0505 REAR