

**V-Twin Mfg.
Replica Oil Pump Assembly
Fits 1957-1966 XL Models
VT Part No. 12-9979**

This is a custom application and rider safety depends on proper installation. This product should only be installed by a knowledgeable and trained motorcycle technician. V-Twin Mfg. accepts no responsibility for improper installation.

Installation Instructions:

Disassembling and Assembling Oil Pump Check Valve:

1. Thoroughly clean exterior of pump in cleaning solvent before disassembly. Disconnect oil pressure switch wire and disassemble switch (1) from motorcycle. Remove oil pump nipple (2). Free check valve spring (3) and valve (4) from pump body.

Cleaning and Inspecting Oil Pump Check Valve:

1. Clean all parts in cleaning solvent. Blowout pump nipple (2) oil passage and the nipple valve spring guide. Examine the nipple for any damage that would bind or hinder the free operation of spring (3). Carefully examine the nipple threads for wear; if badly worn replace nipple.
2. Inspect spring (3) for breakage and rusted condition. Replace if worn or damaged. Free length of new check valve spring (3) is approximately 1-15/64 in.
3. Carefully inspect the oil pump check valve ball (4) for wear and rusted condition. Valve may have rings formed by action on valve seat. Valve balls not perfectly smooth and round should be replaced.
4. Using a light, inspect valve seat in pump body (16) for pits and for dirty condition. A small particle of foreign matter lodged on valve seat will prevent check valve ball from seating. If seat is only slightly damaged place check valve ball on seat and with a drift lightly tap against its seat to remove slight marks or pits. Replace pump body if valve seat is badly damaged. See "disassembling oil pump below."

Assembling Oil Pump Check Valve:

1. Assembly is essentially the reverse order of disassembly. Apply a light coating of oil to all moving parts. Make sure that check valve ball (4) is correctly seated and valve action is free. Be extremely careful to prevent dust, dirt or other foreign particles from getting on the parts when reassembling.

Disassembling Oil Pump:

1. Because of interference from motorcycle frame it is necessary to remove engine to disassemble pump. First, remove the engine complete from the chassis and position on workbench. See "stripping motorcycle for engine repair" in your service manual.

Note: It is not necessary to remove valve tappets and valve tappet guides to service the oil pump.

2. The breather is a part of and drives the oil pump. When removing the oil pump, the breather will of course come out with it. Removing the pump does not require removing the circuit breaker, gearcase cover or removing timing gears. However, it must be remembered that in order to correctly time breather and to check oil pump alignment, it is necessary to remove these parts.
3. Thoroughly clean exterior of pump with cleaning solvent before further disassembly. Remove the five crankcase stud nuts that secure the oil pump to the crankcase. Slip the pump off the studs as one unit. If difficult to remove, take a piece of brass and tap on breather sleeve that extends into gearcase compartment. To disassemble the check valve see "disassembling oil pump check valve" in your service manual.
4. Free the oil pump body plate (5) from pump body. Discard gasket (6). Remove split key (7), remove scavenger gears (8) and (9). Remove key (10). Free oil feed pump cover (11) and breather valve (19) as one assembly from pump body. Discard gasket (12). Free gears (13 and 14) from pump body. Pry oil seal (15) from pump body (16) and discard seal. Discard gasket (17).
5. With a punch remove lock pin (18) and free oil pump breather valve gear and shaft (19) from oil pump cover (11).

Note: Remove lock pin (18) only if inspection or replacement of shaft (19) and cover (11) is necessary.

6. Remove breather valve screen (20) from crankcase. Remove idler gear shaft (21) only if replacement is necessary. Shaft is a press fit.

Cleaning and Inspecting:

1. First clean all parts in cleaning solvent. Blowout all oil holes and passages with compressed air. Replace any parts that are worn or damaged.
2. Replace all gaskets (6, 12 and 17), lock pin (18) and oil pump seal (15) when reassembling. Be sure to always install new "factory made" gaskets. Never use "homemade" gaskets because they are a specified thickness with holes especially located for oil passage.
3. Check gear side clearance as follows: When feed gears are inserted in pump body, gear faces should be no more than .0005 in. below to .0025 in. above body gasket surface.
4. Carefully examine the pump body (16) for any wear. See "cleaning and inspecting oil pump check valve."
5. Examine gears (8, 9, 13 and 14) and oil pump breather shaft (19) and idler gear shaft (21) for damage or wear. If the breather valve key (10) is excessively worn and loose on shaft or gear, replace with a new one. Inspect pump body plate (5) and cover (11). If they are worn or damaged, replace them. Examine breather valve (19) and oil pump cover for any wear or damage that might affect its operation. Insert breather valve (19) in oil pump cover (11). Make sure valve turns freely in cover and does not bind.

Assembling Oil Pump:

1. Reassembly of the oil pump is essentially the reverse order of disassembly.
2. Apply a light coating of engine oil to all moving parts before assembling.
3. Reassemble check valve. See assembling oil pump check valve above.

4. Position breather valve screen (20) in crankcase using grease to hold in place. Insert breather valve gear and shaft (19) in oil pump cover (11). Press a new drive lock pin (18) into breather valve shaft. Lock pins are often damaged when removed; therefore, install new ones when reassembling pump.
5. Press a new idler gear shaft (21) into pump body (16). Place gears (13 and 14) in pump body and install a new gasket (12) being very careful to correctly align the oil holes of the gasket with the pump body. Use a non-hardening gasket sealer.
6. Install oil pump breather valve gear, shaft and cover assembly on pump body (16). Place a very thin strip of acetate (Scotch) tape over shaft lock ring groove to avoid damaging new oil seal (15). Install seal carefully over shaft with lip side facing pump body, then remove tape from shaft. Press seal into body counter bore flush with surface.
7. Install gear key (10) and gears (8 and 9). Install retaining keys (7) in breather valve shaft groove. Assemble a new gasket (6) in place using a non-hardening gasket sealer. (If gasket is exceptionally dry and curled up, soak in water for a few minutes to soften before applying gasket sealer.) Position oil pump body plate (5) and install assembled pump in place on engine crankcase studs. Snug up the oil pump stud nuts evenly. Then, working opposite one another, tighten to 100 in-lbs torque to ensure correct alignment of the oil pump.
8. Before installing gears on pinion shaft, make sure pump gears turn with little or no binding. While a very slight bind or drag is permissible, gears should turn freely as possible. Binding is caused by slight misalignment of pump. If there is more than just noticeable bind, loosen five mounting stud nuts and shift pump as needed by tapping lightly with a soft mallet. It will not be possible to determine before hand in which direction pump must be shifted and it may require several attempts from different angles before alignment is attained.
9. After the oil pump is completely assembled to the crankcase and correctly aligned, it is necessary to open gearcase in order to time the breather valve. Disassemble timing gears, gearcase cover, circuit breaker and push rods; and time breather as described subsequently under Heading "gearcase and timing gears." Install engine in frame as described in the service manual.

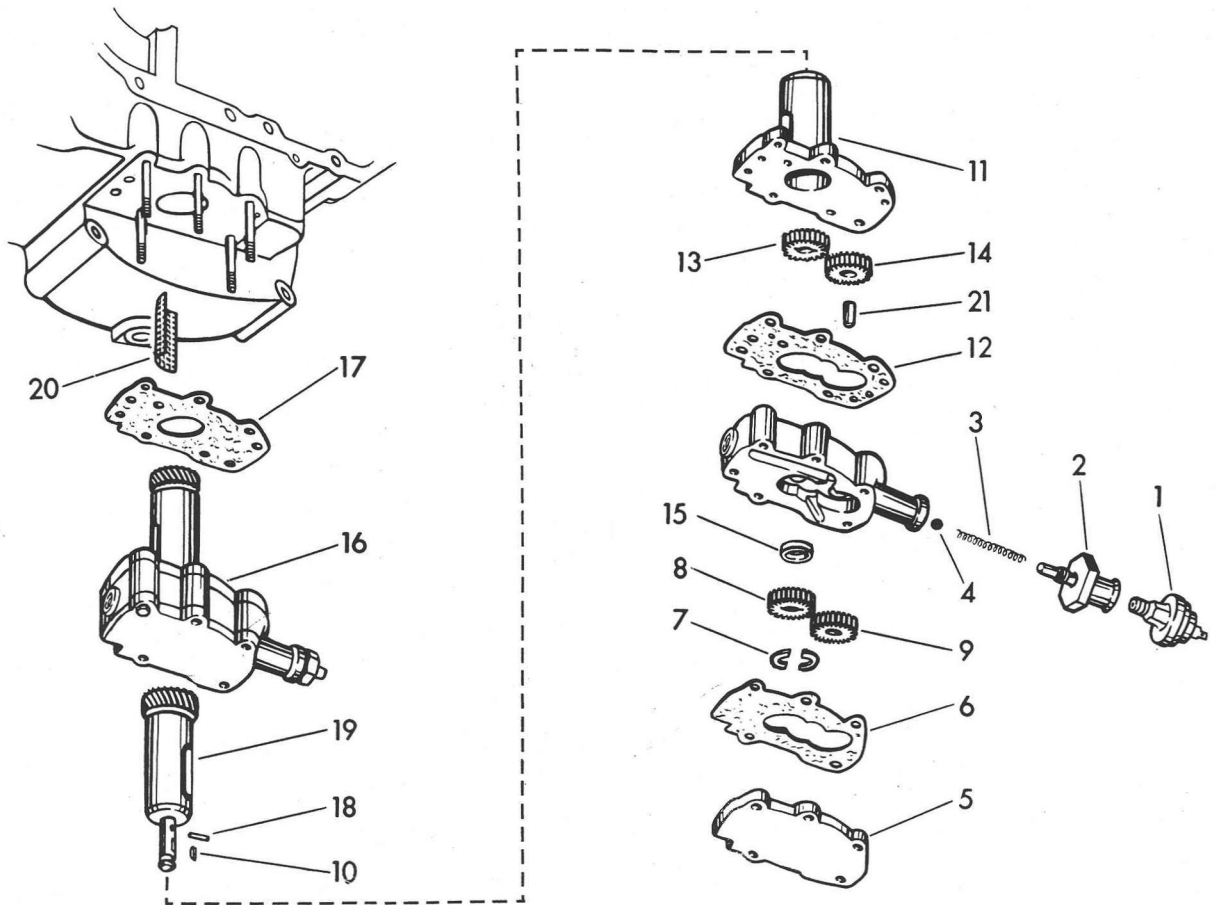

- | | | |
|-----------------------------|------------------------------|-------------------------------------|
| 1. Oil pressure switch | 9. Scavenger pump idler gear | 17. Body gasket |
| 2. Oil pump nipple | 10. Breather valve key | 18. Drive lock pin |
| 3. Check valve spring | 11. Oil pump cover | 19. Breather valve gear and shaft |
| 4. Ball valve | 12. Body cover gasket | 20. Crankcase breather valve screen |
| 5. Body plate | 13. Pump gear | 21. Idler gear shaft |
| 6. Body plate gasket | 14. Pump idler gear | 22. Feed line nipple |
| 7. Retainer (2) (half ring) | 15. Oil pump seal | |
| 8. Scavenger pump gear | 16. Oil pump body | |