

CHROME DISPLAY STAND

GENERAL

Kit Number

91573-09A

Installation Requirements

! WARNING

The rider's safety depends upon the correct installation of this kit. Use the appropriate service manual procedures. If the procedure is not within your capabilities or you do not have the correct tools, have a dealer perform the installation. Improper installation of this kit could result in death or serious injury.

NOTES

This instruction sheet references service manual information. A service manual for your model motorcycle is required for this installation.

Before installing this kit, inspect the frame support bracket flanges for dents or bent areas.

LOCTITE® 271 Threadlocker and Sealant - Red (99671-97) is required to complete this installation and is available from a dealer.

Kit Contents

See Figure 2 and Table 1.

INSTALLATION

! WARNING

To prevent accidental vehicle start-up, which could cause death or serious injury, disconnect negative (-) battery cable before proceeding.

! WARNING

To prevent accidental vehicle start-up, which could cause death or serious injury, remove main fuse before proceeding.

1. Refer to the service manual and disconnect the battery negative cable or remove the main fuse.

NOTE

Make sure that the cutout (B) of the strap (3) is oriented rearward after installation.

2. See Figure 2. Install strap (3) and weld nut (4) to the frame in the locations shown.
3. Position the center display stand over the mounting holes under the frame, oriented with the skid plate forward.
4. Apply Loctite 271 - Red to the two long screws (1). Secure the rear of the display stand to the frame by installing the screws to the strap.
5. Apply Loctite 271 - Red to the short screw (2). Secure the front of the display stand to the frame by installing the screw to the weld nut.
6. Tighten screws to 60-96 in-lbs (7-11 Nm).
7. Refer to the service manual and connect the battery cables or install the main fuse.

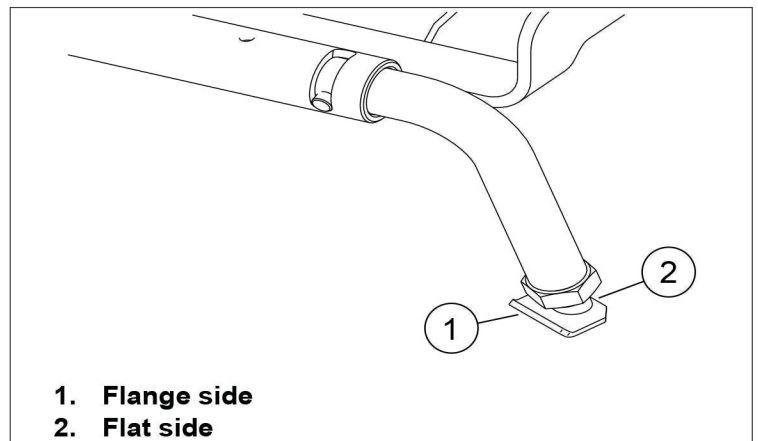

Figure 1. Chrome Display Stand Foot Orientation

ADJUSTING THE DISPLAY STAND

To level the motorcycle and adjust the height, adjust each foot as necessary. To adjust the display stand:

NOTE

The display stand can be adjusted with rear tire to ground contact or with rear tire off the ground. With the rear tire to ground contact adjustment, the rear wheel is on the ground but enough weight is on the display stand legs to make the motorcycle stable from side-to-side and front-to-back. Using the display stand to center the motorcycle requires effort. With the rear tire off the ground adjustment, the rear tire clears the ground so tire can be rotated for cleaning or maintenance. Using the display stand to lift rear tire off the ground requires more effort.

Do not center the vehicle with someone on the vehicle. To reduce effort, remove stored items from saddlebags.

Adjustment Procedure - Rear Wheel on Ground

NOTE

Adjust left and right foot pads with the display stand retracted and the jiffy stand down to prevent the motorcycle from falling over.

1. Adjust the feet of the display stand so that there is 0.75 in (19 mm) of thread engagement into the stand. Verify that the jamnuts remain loose.
2. Engage the stand (See Using the Display Stand). Measure the distance from the bottom of the rear wheel to the ground.
3. Turn the adjuster feet in the distance previously measured.

NOTE

Because the jamnuts are loose, the foot pads can adjust to floor.

4. Engage the stand.
5. See Figure 1. Verify that both foot pads and rear wheel are making solid contact with the ground and that the motorcycle is level and stable. Verify that the foot pads are oriented with the flange side (1) facing to the rear and the flat side facing the front (2). If the stand needs adjustment, retract the display stand. Adjust foot pads and then engage the stand again. Repeat this step as necessary.
6. Tighten the jamnuts securely.

Adjustment Procedure - Rear Wheel Raised

NOTE

Adjust left and right foot pads with the display stand retracted and the jiffy stand down to prevent the motorcycle from falling over.

1. Adjust the feet of the display stand so that there is 0.75 in (19 mm) of thread engagement into the stand.
2. Adjust the feet as necessary so the motorcycle is level when the display stand is engaged. Leave the jamnuts loose.

NOTE

The foot pads can adjust to floor when the jamnuts are loose.

3. Engage the stand. (See Using the Display Stand)
4. See Figure 1. Verify that the motorcycle is level and stable. Verify that the foot pads are oriented with the flange side (1) facing to the rear and the flat side facing the front (2). If the stand needs adjustment, retract the display stand. Adjust foot pads and then engage the stand again. Repeat this step as necessary.
5. Verify that the display stand does not make contact with the exhaust system. If the display stand contacts the

exhaust system, make the following adjustments in order until contact is eliminated:

- a. Adjust the foot pads to reduce the motorcycle display height, if possible.
 - b. Loosen the display stand mounting hardware (Figure 1, items 1 and 2). Move the display stand as far forward as possible. Tighten the mounting hardware to specification.
 - c. See the service manual. Loosen exhaust system mounting hardware. Move the exhaust system rearward, if possible. It will not move far. Then tighten exhaust system to specification.
6. Tighten the jamnuts securely.

USING THE DISPLAY STAND

Engage Display Stand:

WARNING

When using this display stand, do not park on inclined surfaces with the motorcycle front pointing downhill. The vehicle could roll off the stand and fall, resulting in death or serious injury.

WARNING

Never start engine when motorcycle is on display stand. Motorcycle could fall resulting in death or serious injury.

1. Park the motorcycle in on a level surface in neutral. Stand on the left side of the vehicle, lift the left passenger footboard or peg.
2. Hold the left grip with your left hand, straighten front wheel and then hold the left rear fender with your right hand.
3. See Figure 2. Place your right foot on the display stand foot lever (A) to lower the display stand foot pads to the floor.
4. Brace your right foot against the foot lever. Push the lever towards the floor. Center vehicle on both feet.
5. Once centered on both feet, push down on lever and lift vehicle rearward to ease the vehicle onto the display stand.

Retract Display Stand:

NOTES

The display stand **MUST** not contact exhaust system or the rear passenger footboard supports. Verify that the display stand does not contact the exhaust system.

A grease fitting is provided at the rear center of the stand. Lubricate the stand at regular intervals with a good quality grease.

When using a motorcycle lifting device, do not allow motorcycle lifting device to come in contact with the display stand. Damage can occur to display stand.

The center display stand can be retracted with the rider on the vehicle or when one is standing next to the left side of the vehicle.

1. Park the motorcycle in on a level surface in neutral. Hold the left grip with your left hand and then hold the right grip with your right hand covering the front hand brake lever. display stand, use front brake lever as needed until display stand disengages.
2. Push forward (toward the front of motorcycle) on handlebar grips until display stand is retracted. As vehicle comes off
3. Retract the jiffy stand.

SERVICE PARTS

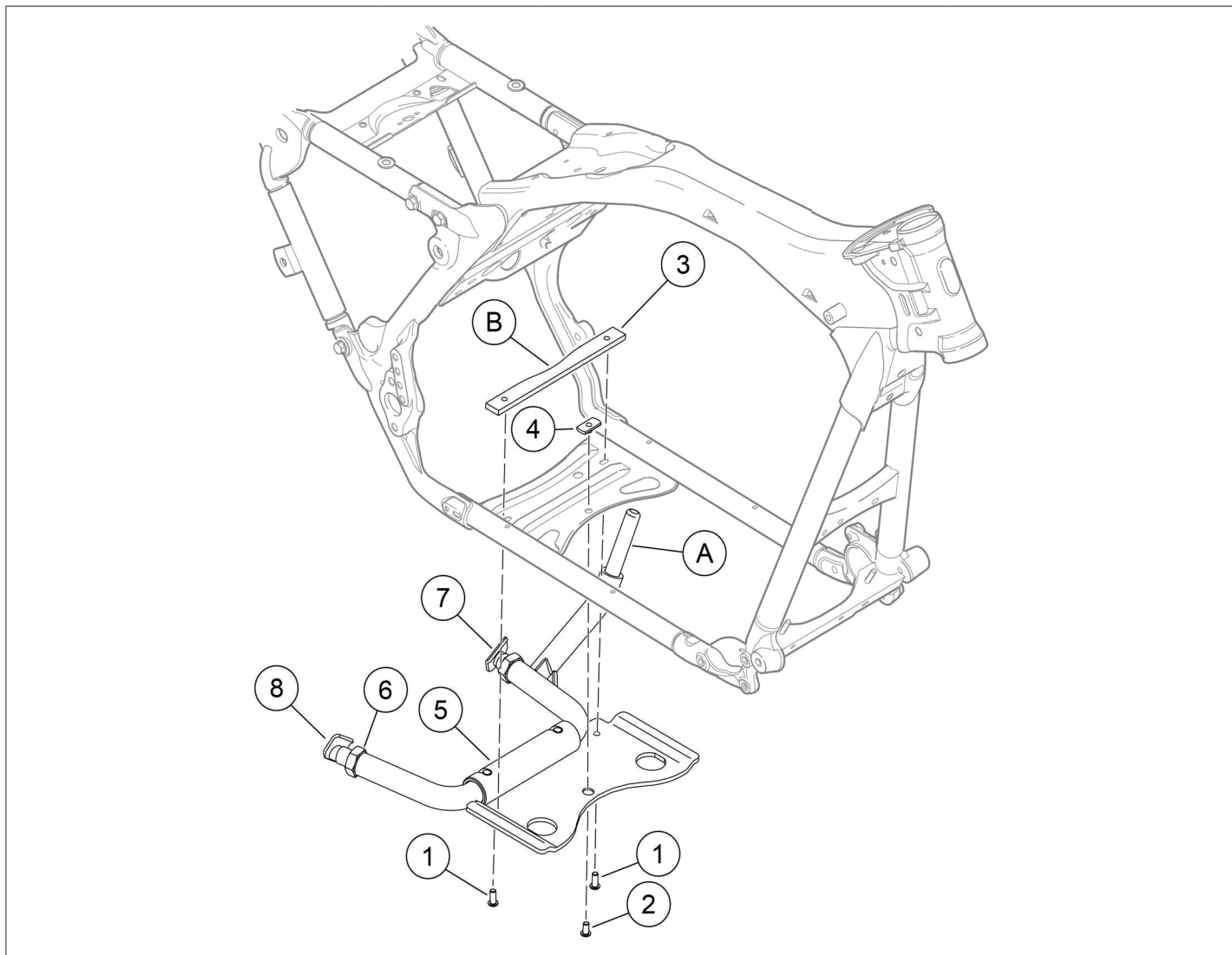

Figure 2. Service Parts for Center Display Stand

Table 1. Service Parts Table

Item	Description (Quantity)	Part Number
1	Screw, long (2)	926
2	Screw, short	3063
3	Strap	Not Sold Separately
4	Weld nut	Not Sold Separately
5	Center display stand	Not Sold Separately
6	Jam nut (2)	7855W
7	Assembly, foot, left side	Not Sold Separately
8	Assembly, foot, right side	Not Sold Separately
Items mentioned in text		
A	Foot lever	
B	Strap cutout	