

VT No. 23-9238

ABUTMENT SHIM

General

This abutment shim is for installation in the rear caliper mounting brackets on 1982 and later XLs, 1982 and later FXRs, 1983 and later FXWG and FXSB, and 1983 FLHS.

NOTE

Abutment shims normally do not need to be replaced; but, they must be replaced if lost or damaged.

Installation

1. Refer to the applicable Service Manual for instructions covering the removal of the rear brake caliper and brake pads.
2. See Figure 1. The stainless steel abutment shims are located on the rear caliper mounting bracket in the area where the brake pads are contained. (Figure 1 shows the bracket used on the FXWG, FXSB and FLHS; the other brackets are similar.)
3. Remove all the existing adhesive from the mounting bracket surface where the abutment shim is located. The surface should be scraped with a knife and, if required, lightly sanded with fine emery cloth.
4. Clean the surface scraped and sanded in Step 3 above with denatured alcohol.
5. Apply a silicone sealant to the bracket surface and install the abutment shim. To hold the shims in position, install the brake pads in the bracket.
6. Allow the silicone sealant to dry.
7. Check that the brake pads slide freely in the bracket.
8. Refer to the applicable Service Manual for reassembly instructions for replacing the brake caliper.

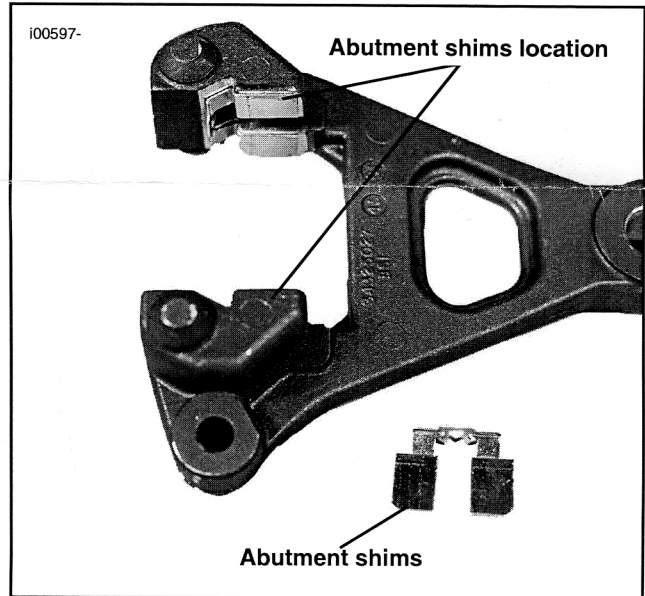

Figure 1. Location of Abutment Shims