

# REDUCED REACH FOOTBOARD SUPPORT KIT

## ⚠ WARNING

The rider's safety depends upon the correct installation of this kit. If the procedure is not within your capabilities or you do not have the correct tools, have a dealer perform the installation. Improper installation of this kit could result in death or serious injury.

### Additional Contents

This kit does not include footboards. Stock footboards may be re-used or purchased separately.

### Kit Contents

See Figure 2 and Table 1.

## REMOVAL

1. Remove passenger footboard and support assemblies from motorcycle.
2. See Figure 1. Remove footboard (8) from footboard supports by carefully lifting up the inside corners of the rubber footboard insert (9) to expose the pivot pins. Do not remove the footboard insert from the footboard pan as it can be difficult to install.
3. Remove pivot pins (3) by pushing pins toward the outside of the footboard until the footboard is free of the mounting lugs. Be aware that the springs (4) and balls (5) may fall out when the footboard pan is removed.
4. Remove the springs (4) and balls (5). Save for installation.

## INSTALLATION

### NOTES

- *If necessary, remove any paint from counterbore holes of footboard brackets to ease the installation of the pivot pins.*
  - **On 2010-Later Models:** The installation height can be adjusted to one of three positions. To install footboards in a new position, remove plastic plugs from holes in rear swingarm bracket as necessary.
  - **On 2009-Earlier Models:** The lowest of the three holes on the frame is not threaded and cannot be used to mount the footboards.
1. See Figure 2. Insert shoulder bolt (2) through slot in footboard bracket (1) and into hole in rear swingarm bracket at the desired height. Tighten to 48-72 **in-lb** (5-8 Nm).
  2. Install the upper screw (3) and lockwasher (4) through footboard bracket (1). Tighten screw to 36-42 **ft-lb** (49-56 Nm).

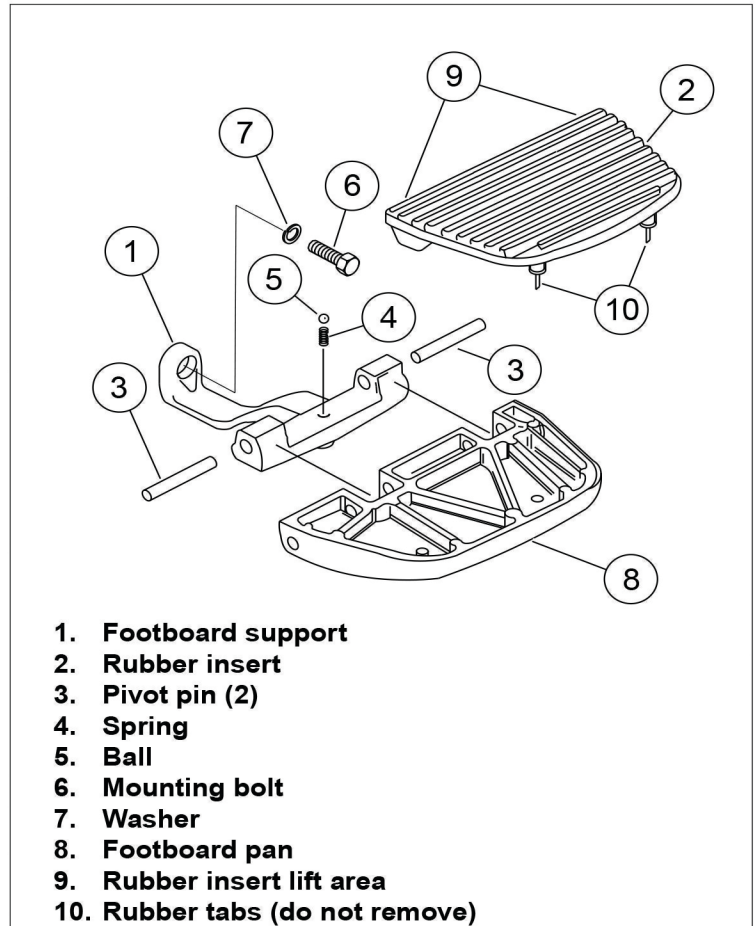
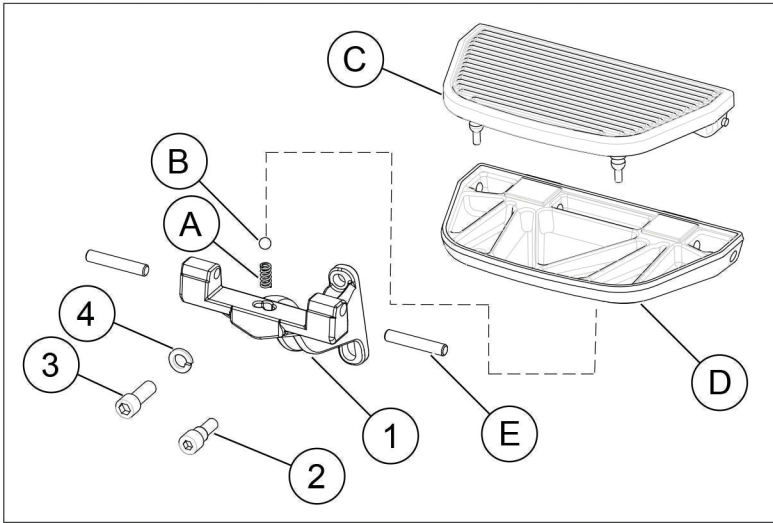

**Figure 1. Stock Footboard Mounting**

3. Install spring (A) into retaining hole in footboard bracket. Set the ball (B) on top of spring.
4. Position the detent in the bottom of the footboard pan (D) over ball in footboard bracket. Be sure not to unseat the ball.  
Press down on footboard pan so the holes of the footboard pan and footboard bracket align.
5. Insert pivot pins (E) through two mounting holes on footboard bracket and into footboard pan.
6. If removed, align footboard insert in footboard pan. Firmly press footboard insert until the rubber tabs pass through holes in footboard pan.
7. Pivot footboard assembly up and down to verify proper operation.
8. Repeat all steps for opposite side.

**Table 1. Kit Components**

Item	Description (Quantity)	
1	Footboard bracket (2)	
2	Shoulder bolt (2)	
3	Screw, socket head cap (2)	
4	Lockwasher (2)	
<b>Items referenced in text, but not provided in kit:</b>		
A	Spring (2)	
B	Ball (2)	
C	Footboard insert (2)	
D	Footboard pan (2)	
E	Pivot pin (4)	



**Figure 2. Service Parts: Reduced Reach Footboard Support Kit**