

**V-Twin Mfg.**  
**AIR CLEANER MOUNT KIT**  
**Fits 1991 and Later XL and 1993 and Later BT Models**  
**VT No. 31-0430 & 31-0431**

**This is a custom application and rider safety depends on proper installation. This product should only be installed by a knowledgeable and trained motorcycle technician. V-Twin Mfg. accepts no responsibility for improper installation.**

**Installation Instructions:**

1. Loosely install brackets on back of air cleaner backplate by inserting bolts, washers and lockwashers included with kit, through slotted holes in bracket and into two tapped holes in plate. See Photo below. On Dyna Models see note below.

**NOTE:** On Dyna models use 1-1/4 in. bolts and 4 spacers with all other 1340 models use 1 in. bolts and 2 spacers.

2. On 1340 models only, install spacers onto bolts as shown. Tighten bolts only until they hold bracket loosely to plate.
3. Place one gasket over each banjo bolt. Insert bolts through holes in mounting brackets. Place a second gasket over bolts. Position manifold assembly over banjo bolts with hose fitting on manifold to rear of motorcycle. Install remaining gaskets over the ends of banjo bolts.
4. On FXD models only, install spacer (18) and gasket (17) onto backplate using mounting screws from kit.
5. Holding assembly together, insert banjo bolts into tapped holes in cylinder head. Tighten each bolt a little at a time, until assembly is held loosely in place. On Dyna models only, tighten bolts to 3 - 5 ft-lbs.
6. On all models except the Dyna, line up the three center holes in your backplate with corresponding tapped holes in carburetor.
7. Secure backplate to carburetor using three bolts from your air cleaner kit. Tighten bolts to 3 - 5 ft-lbs.
8. Tighten banjo bolts to 10 - 12 ft-lbs.
9. Tighten bolts holding backplate to brackets, until secure.
10. Install one end of hose on manifold fitting. Install other end to 90° fitting on your backing plate or attach to a breather filter.

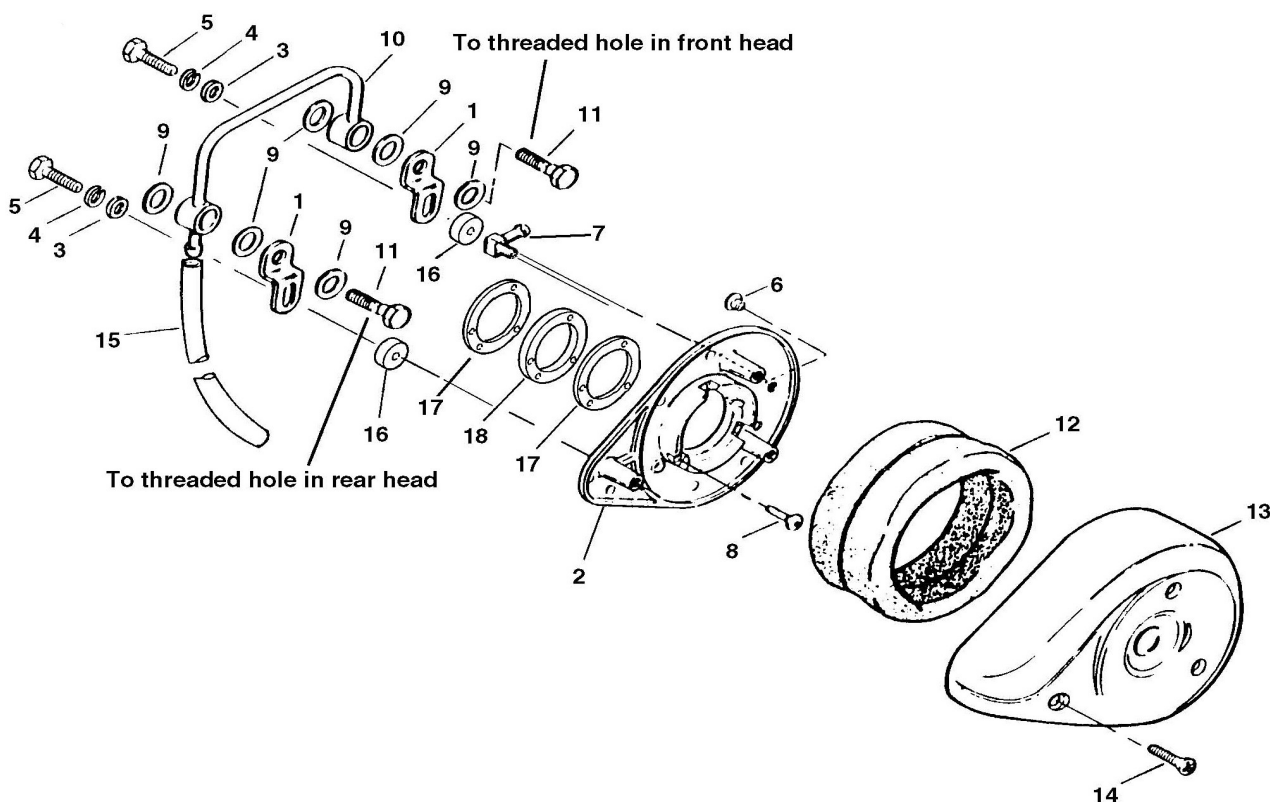

**Parts List:**

- |   |   |
|---|---|
| 1. Backplate bracket *                      | 13. Cover*  |
| 2. Backplate*                               | 14. Cover screw*  |
| 3. Flat washer                              | 15. Hose  |
| 4. Lock washer                              | 16. Spacer, for use on 1340 models, except Dyna Models                        |
| 5. Bolt, 1" (XL and 1340 except Dyna)       | 17. Air cleaner gasket (FXD Models use two gaskets, all other models use one) |
| Bolt, 1-1/4 in. (Dyna models only) Not Inc. | 18. Air cleaner spacer (FXD Models)   |
| 6. Plug*                                    | * Indicates that part is found in Air Cleaner Kit                             |
| 7. Hose fitting, 90°*                       |   |
| 8. Captive screw*                           |   |
| 9. Gasket*                                  |   |
| 10. Manifold assembly                       |   |
| 11. Banjo bolt                              |   |
| 12. Filter element*                         |   |