

VT No. 31-4019 "T" Kit for FXST-FLST Solo Seat Mount Kit

includes heavy duty "T", 5" chrome springs, and hardware for mounting on 1984-up models. Will accept our seats 47-0511, 47-0512, 47-8655, 47-0110 and our Buddy and Heritage models. Strut bars are included to mount seat rigidly but still retain the springs from early look. Seat can be spring mounted, but realize the seat and mount will not be as stable as a rigid mount, and adequate clearance must be allowed between the seat and rear fender. "T" and brackets are finished in black. Buddy seats will require purchase of front nose bracket VT No. 31-0177, to bolt to front of "T". Also holes in rear of seat "T" are countersunk to allow Buddy Seat rear brackets. Use "K" countersunk washers inside of spring to center spring bolt.

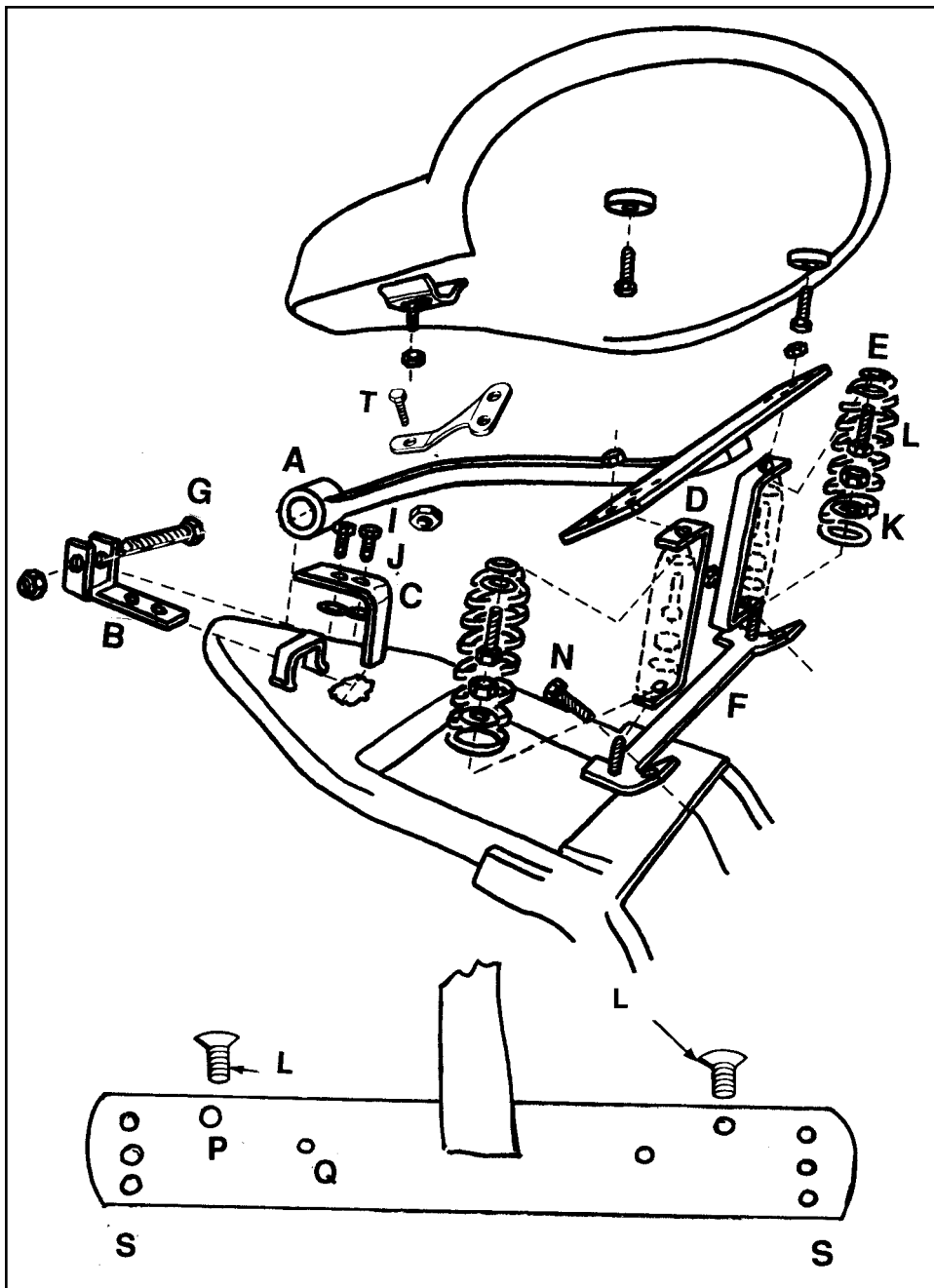

Parts includes in the kit are the following:

Qty	#	Item
1	A	Seat T
1	B	Pivot Bracket
1	C	Pivot Clamp
2	D	Strut Bars
2	E	5" Springs
1	F	Lower Spring Mount
1	G	3/8 x 24 x 2 Hex Bolt
1	H	3/8 x 24 Nyloc Nut
2	I	5/16 x 24 x 3/4 Hex Bolt
2	J	5/16 Lock washer
4	K	Countersunk Washer
2	L	5/16 x 18 x 1 1/4 Flathead Screw
4	M	5/16 x 18 Nyloc Nut
2	N	3/8 x 16 x 3/4 Hex Bolt
2	O	3/8 Lockwasher
1	T	3/8 x 24 x 1 1/4 Hex Bolt



Bracket **VT No. 31-0177** is used for front Buddy seat mounting and is not included with kit. Rear "T" bar shown holes "S" are to mount Police Solo and Buddy rear brackets hole "P" to mount top of spring must be countersunk when Buddy seat and use 5/16 x 1 1/4" flat head screw. Hole "Q" for K model or narrow seats. Rear T may be drilled for other combination.