

V-Twin Mfg.  
CRANE 8-1100 DUAL FIRE IGNITION  
VT No. 32-9217

This is a custom application and rider safety depends on proper installation. This product should only be installed by a knowledgeable and trained motorcycle technician. V-Twin Mfg. accepts no responsibility for improper installation.

**CAUTION: READ INSTRUCTIONS CAREFULLY BEFORE STARTING INSTALLATION**

**INTRODUCTION**

The HI-4 ignition system is intended for use with Harley-Davidson® motorcycles. The HI-4 replaces the original equipment (OE) electronic ignition system on 1978 and later models as well as the points and mechanical advance on early models.

**WARNING: 1996 and later models have a vehicle tilt sensor that shuts off the ignition if the motorcycle rolls on its side. This feature is disabled when the HI-4 ignition is installed.**

The HI-4 features state-of-the-art RISC microcontroller technology that allows an adjustable advance and rev limit. A timing LED indicates static timing (top dead center) and gives diagnostic information. Two starting modes are provided: electric start and kick start. A tach output insures accurate tach readings even at the rev limit.

**NOTE: HI-4 Dual Fire Race Ignition 8-1100 is for off road racing and early OE points applications only.**

**ADDITIONAL REQUIRED PARTS**

FX and XL models prior to 1984, FL models prior to 1985, and all models with OE points will require OE timing rotor P/N 32402-83. This part is not included with the HI-4 installation kit and can be purchased from your local dealer.

**COIL AND SPARK PLUG CABLE CONSIDERATIONS**

We recommend replacing the OE coil. Coils used with the HI-4 must have at least 2 ohms primary resistance. Coils with 4 ohms or higher may be used, but may not produce optimum output. Use of Crane Cams P/N 8-3006 coil will provide optimum performance and output.

Crane Cams FireWire spiral core wires are recommended for maximum performance. Do not use non-suppression solid core spark plug wires; they may cause interference with your electronic ignition system and/or accessories.

**REMOVAL OF POINTS IGNITION - 1970 TO 1977 MODELS**

1. Turn ignition switch off and disconnect battery ground cable. Disconnect wire going from breaker points to Coil negative terminal.
2. Refer to Figure 1. Remove ignition cover plate, gasket, and hardware (items 1-3). Save these items for later re-use.
3. Note location of breaker plate. There is a V notch in the breaker plate used for alignment. When you install the HI-4, you should align the V notch in the same location. This should set the timing close enough to start the engine. Remove and save the two standoffs and washers (items 4-5). Remove the breaker plate assembly, wiring, cam, and advance assembly (items 6-10).

**REMOVAL OF OE ELECTRONIC IGNITION SYSTEM - 1978 AND 1979 MODELS**

1. Turn ignition switch off and disconnect battery ground cable.
2. Refer to Figure 2. Disconnect wires going from ignition module (3) to coil (14).
3. Remove ignition cover plate and hardware (items 1 and 2). Save these items for later re-use. Remove ignition module (3).
4. Note location of timer plate (10). There is a V notch in the timer plate used for alignment. When you install the HI-4, you should align the V notch in the same location. This should set the timing close enough to start the engine. Remove and save the

Figure 1. Harley-Davidson® OE Points System

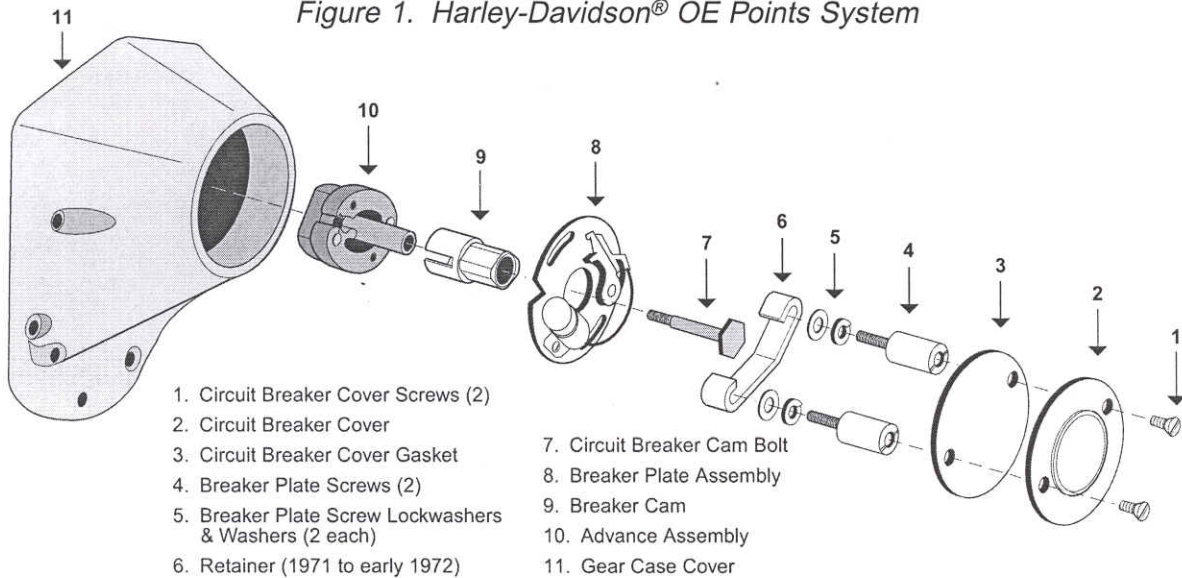

two standoffs and washers (items 4,5). Remove the sensor, shield, timer plate, trigger rotor, and advance assembly (items 6-12).

## REMOVAL OF OE ELECTRONIC IGNITION SYSTEM - 1980 AND LATER MODELS

1. Turn ignition switch off and disconnect battery ground cable.
2. Refer to Figure 3. Remove OE ignition module and wire harness (items 1-4). You will disconnect two wires at the coil (15), a wire going to the VOES (Vacuum Operated Electrical Switch) (18), a black ground wire at the ignition module, and the 3 pin plug (20) that connects to the sensor plate (11). Refer to shop manual for locations.
3. Remove ignition cover plates and gasket (items 5-9). This will require drilling out two rivets. The rivets will later be replaced with two supplied self-threading screws.
4. In order to remove the sensor plate cable, the cable plug (20) must be removed first. Use needle nose pliers to pull the terminals out of the plug. Then pull the cable through the exit hole at the bottom of the timing cover.
5. Note location of sensor plate (11). There is a V notch in the sensor plate used for alignment. When you install the HI-4, you should align the V notch in the same location. This should set the timing close enough to start the engine. Remove and save the two standoffs and washers (10). Remove the sensor plate (11).

## HI-4 INSTALLATION

Refer to Figure 4. The HI-4 requires use of the OE timing rotor P/N 32402-83 (used only on 1985 and newer models). If you have an older model or are not sure, check the rotor (9) for the correct part number. For models prior to 1980, use the supplied 10-32 x ¾" bolt and washer to mount the rotor.

1. Install the HI-4 system in place of the OE breaker or sensor plate. Rotate the HI-4 about 90 degrees to give better access to the cable exit hole. Install the HI-4 first, then push the cable through the hole. On some early models it may be necessary to enlarge the wire harness exit hole in the gear cover. Align the V notch on the HI-4 same as the OE plate you removed. Use the OE standoffs to secure the HI-4. You must use lockwashers under the standoffs for proper clearance between the HI-4 and cover plate. Do not fully tighten the standoffs until the timing has been set.
2. Route the HI-4 wire harness along the frame rails up to the coil. Make sure that harness will not be chafed or burned by exhaust heat. Secure harness with tie wraps. Do not install timing cover.

## HI-4 HOOKUP

Crimp terminals and hardware are supplied for your convenience. Use the ring terminals for coil hookup. Use male-female quick disconnects for connections to the tach and vacuum switch (VOES). Tape up any unused wires.

**NOTE: Damage will result if the brown tach wire comes in contact with +12V.**

1. Identify switched +12 volt wire and tach wire (if equipped) going to the coil. Refer to your service manual, or reconnect the battery and use a test light or voltmeter. The switched +12 volt wire will be hot when the ignition key is turned on.
2. Refer to Figure 5. Connect the HI-4 red wire and switched +12 volt wire to Coil positive.

**NOTE: Most motorcycle coils do not have terminals marked. Use either terminal for Coil+ (positive) and the other one for Coil- (negative).**

3. The HI-4 white wire is not used and should be taped.
4. Connect the HI-4 black wire to the Coil negative terminal.
5. Connect the HI-4 green wire to the vacuum switch (Figure 3, item 18), if used.

6. Connect the HI-4 brown wire to the tach wire, if equipped with tach. Tape up if unused.
7. The HI-4 is grounded via the timing housing; a separate ground connection is not required.
8. Reconnect battery ground cable. Verify proper ground connections to the frame and engine.

**Warning: The HI-4 (8-1100) Dual Fire ignition will not work with 2 plugs per head, dual coil application. Damage will result if attempted. Use the HI-4 (8-2100) single fire ignition for 2 plugs per head applications.**

### VOES HOOKUP

The OE vacuum switch (VOES) is normally an open circuit. Above 3-5 inch-Hg vacuum, the VOES closes and grounds the vacuum input on the OE ignition module. This increases the total advance generated by the OE ignition module. Vacuum advance improves part throttle

Figure 2. Harley-Davidson® 1978-79 OE Electronic System

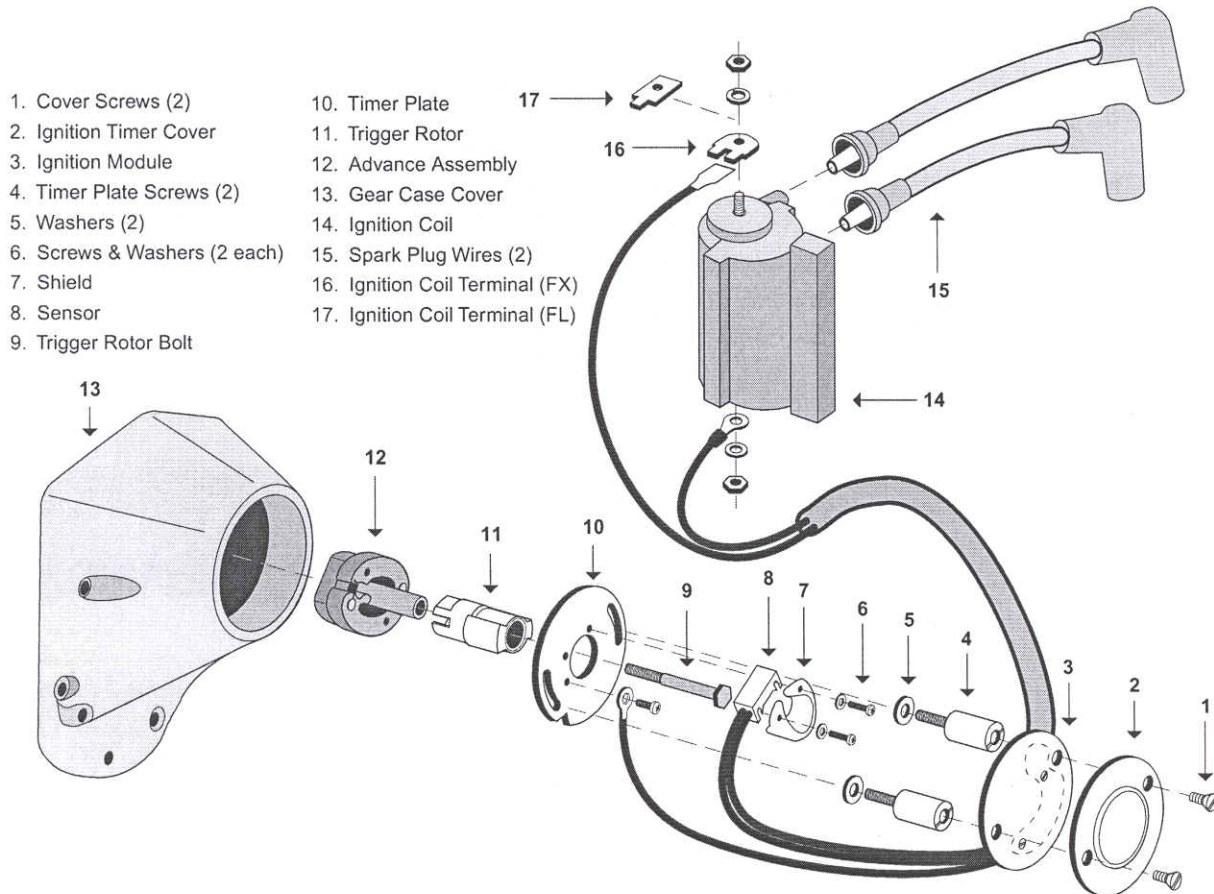

Figure 3. Harley-Davidson® 1980 and Later OE Electronic System

- |  |                            |  |
|--|----------------------------|--|
| 1. Screws (2)                              | 13. Rotor                  | 17. Spark Plug Wires (2)                     |
| 2. Washers (2)                             | 14. Gear Case Cover        | 18. Vacuum Operated Electrical Switch (VOES) |
| 3. Ignition Module                         | 15. Ignition Coil          | 19. VOES Connector                           |
| 4. Well Nuts (2)                           | 16. Ignition Coil Terminal | 20. Sensor Connector                         |
| 5. Rivets (2)                              |                            |  |
| 6. Outer Cover                             |                            |  |
| 7. Inner Cover Screws (2)                  |                            |  |
| 8. Inner Cover                             |                            |  |
| 9. Gasket                                  |                            |  |
| 10. Sensor Plate Screws & Washers (2 each) |                            |  |
| 11. Sensor Plate                           |                            |  |
| 12. Rotor Screw & Star Washer              |                            |  |

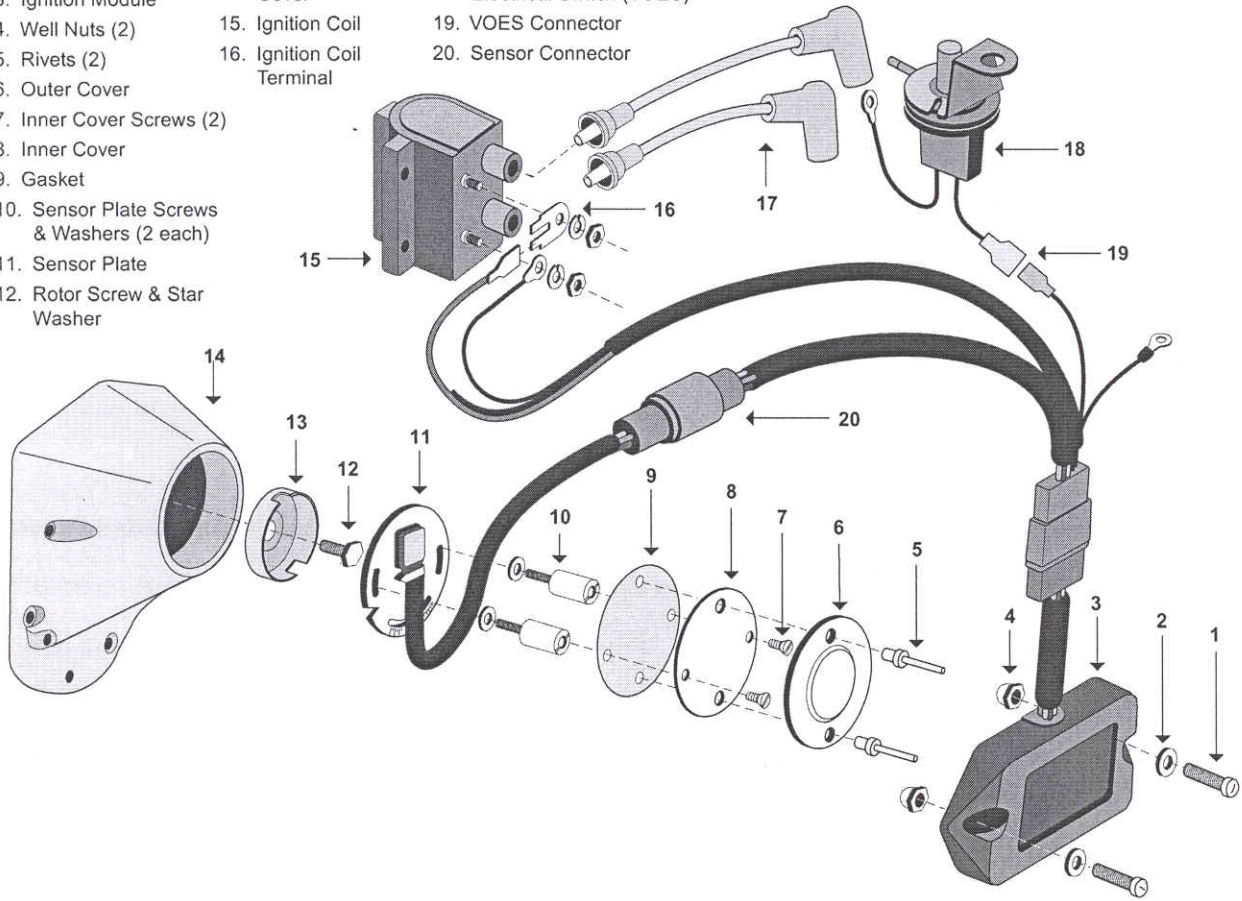
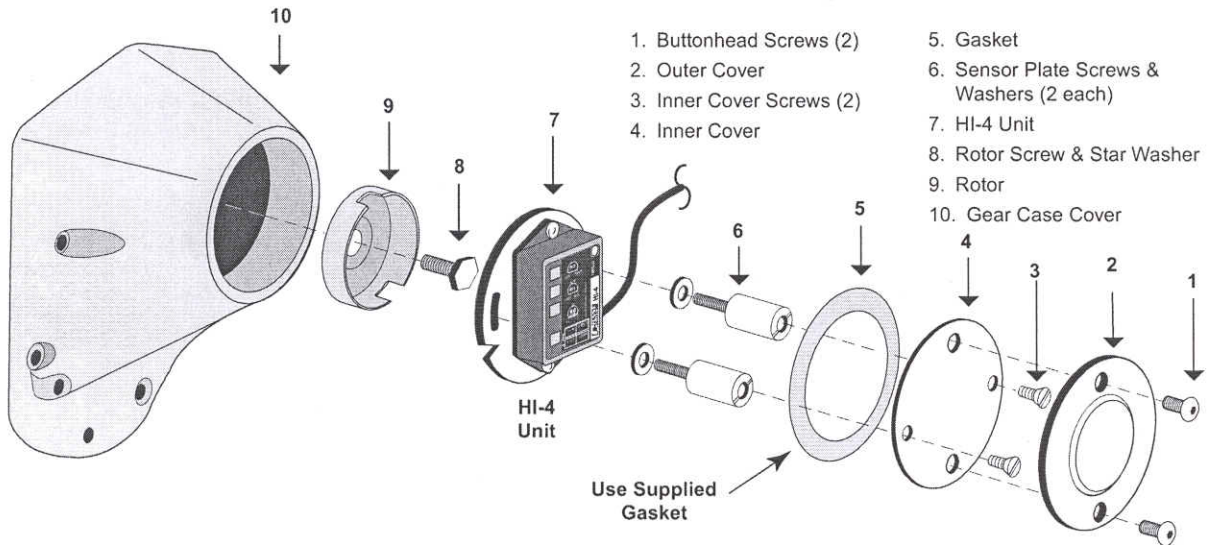

Figure 4. HI-4 Ignition System Installation



- |                           |   |
|---------------------------|---|
| 1. Buttonhead Screws (2)  | 5. Gasket                                 |
| 2. Outer Cover            | 6. Sensor Plate Screws & Washers (2 each) |
| 3. Inner Cover Screws (2) | 7. HI-4 Unit                              |
| 4. Inner Cover            | 8. Rotor Screw & Star Washer              |
|                           | 9. Rotor                                  |
|                           | 10. Gear Case Cover                       |

driveability and fuel economy. Connect the VOES to the HI-4 green wire as shown in Figure 5.

### MODELS WITHOUT OE VACUUM SWITCH (VOES)

This includes most models prior to 1985. Fuel economy and driveability will be improved if you install a VOES and connect it to the HI-4 green wire as shown in

**NOTE: 1996 and later models use a 2 wire connector between the VOES and the OE harness. Connect one wire from the VOES switch to frame ground and connect the other wire to the VOES input (green wire) on the HI-4.**

Figure 5. HI-4 Dual Fire Ignition Hookup

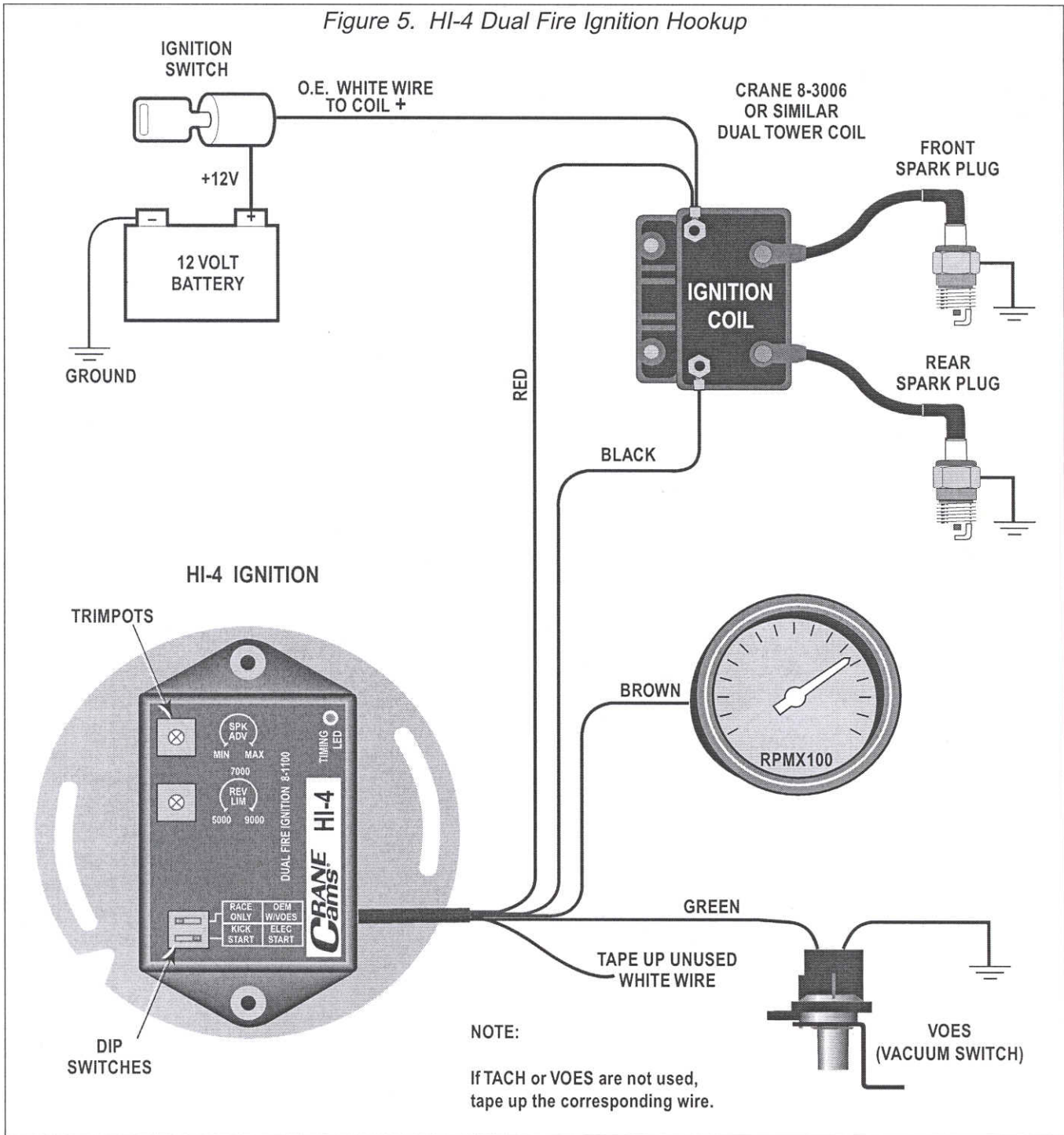

Figure 5. We recommend you use OE VOES P/N 26566-91. If the VOES is not used, tape up the green wire.

## HI-4 SETUP AND OPERATION

Refer to the label on the HI-4. The unit has two DIP switches that select the advance curve and starting mode. The top switch sets the advance curve. Use the OEM with VOES advance curve for stock and modified engines with OE electronic or points ignition. Use the Race Only advance curve for high compression engines. The bottom switch sets the starting mode. Kick start mode fires the first cylinder for quickest starting. Electric start mode delays firing for 2-3 revolutions of the crankshaft for smoother starts and less strain on the starter.

Trimspots on the HI-4 allow adjustment of advance and RPM limit settings. Use the screwdriver supplied in the parts kit to adjust the trimspots. Trimspot setting is indicated by the slot that has two small dots on each side.

**NOTE: Each trimpot can be adjusted over a range of just under one turn. At the ends of the adjustment range, mechanical stops prevent further rotation of the trimpot. Do not attempt to turn the trimspots past their limits.**

The advance curve is adjustable over a limited range via the advance trimpot (SPK ADV). Advance curves are given in Figures 6 and 7. Each set of advance curves includes minimum and maximum curves. The actual advance curve will be between the minimum and maximum curves depending on advance trimpot setting.

If you have a passenger or are using low octane gasoline, minimum advance will reduce spark knock. Maximum advance will give higher performance, but may require the use of high octane gasoline.

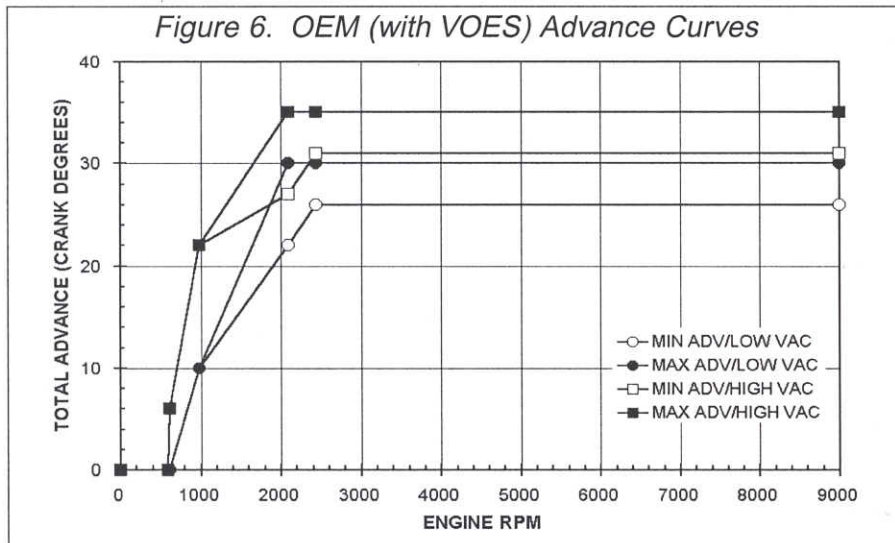

The RPM limit trimpot (REV LIM) is adjustable from 5,000 to 9,000 RPM. Use a safe RPM limit for your engine.

The HI-4 timing LED should light up when the ignition key is turned on. The timing LED will go off when the crankshaft is rotated past TDC. During cranking, the LED will blink.

## TIMING MARKS

The TDC and advance timing marks are located on the flywheel and can be observed via an inspection hole (refer to shop manual for details). Refer to Figure 8 for typical timing marks. Early Style includes most 1980 and earlier models. Late Style includes most 1981-95 models. If the shop manual is not available, remove spark plugs, turn engine until front piston is at TDC on compression stroke and identify TDC mark on the flywheel. Refer to Figure 8 and find the diagram with a matching TDC mark. Use the corresponding advance mark shown in the diagram.

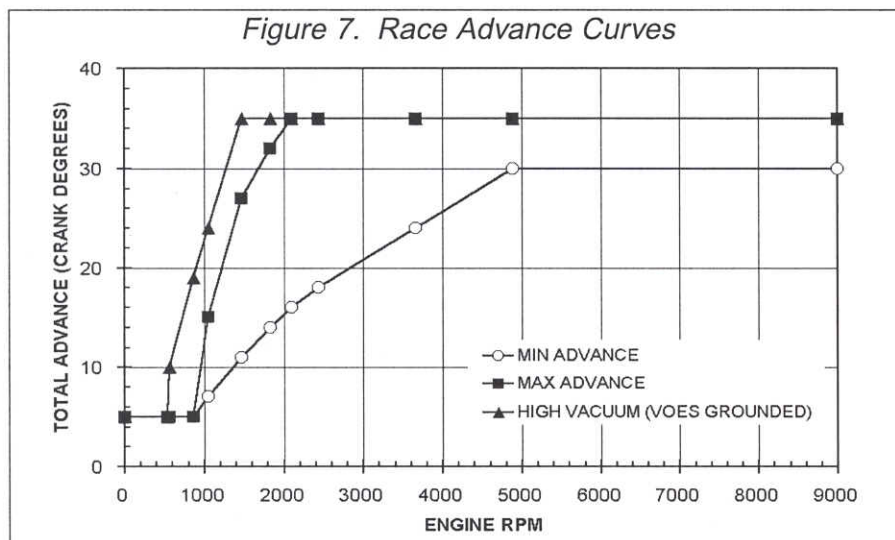
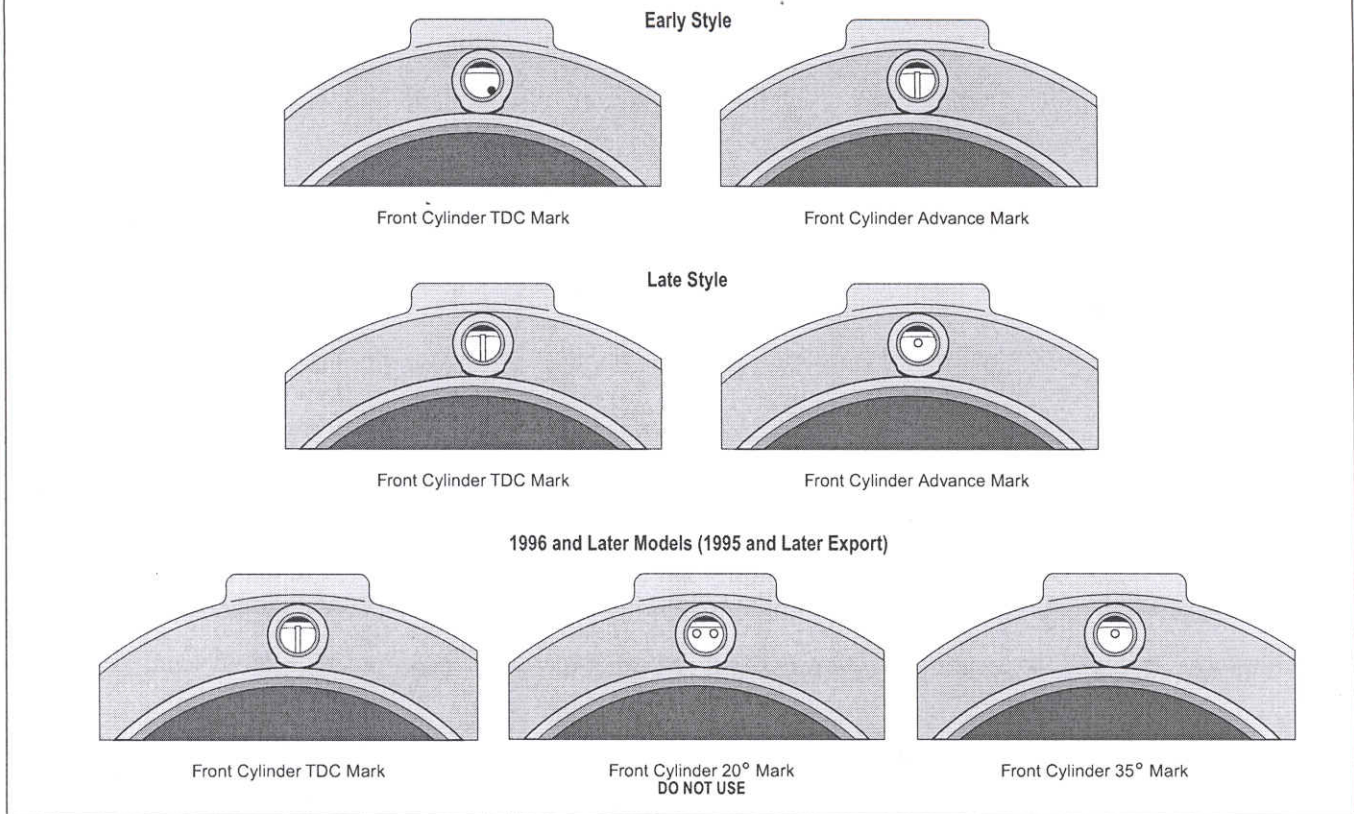

Figure 8. Top Dead Center (TDC) and Front Cylinder Advance Marks for Various Models



**NOTE:** 1996 and later models (1995 and later for export models) have a timing mark at 20° BTDC for setting the timing with the OE ignition module. Do not use this mark for setting the timing on the HI-4. In most cases an additional mark will remain at 35° BTDC (see Figure 8). Use this mark to set the timing with a timing light as described below.

### INITIAL STATIC TIMING PROCEDURE

In most cases, aligning the V notch on the HI-4 plate to the same location as the OE plate will set the timing close enough to start the engine. If the engine will not start or runs very rough, you can use the following static timing procedure.

Remove spark plugs and turn the engine over until the TDC mark appears in observation hole. Ground spark plugs with an alligator clip so you will not shock yourself. Turn on the ignition but do not start the motorcycle. Loosen the standoffs holding HI-4 and rotate the unit

clockwise until the timing LED goes out. The point at which the timing LED goes off is TDC. Timing is now set approximately at TDC. Turn off ignition and re-install spark plugs. Once the engine has been started, you must set the timing with a timing light.

### SETTING ADVANCE TIMING USING STANDARD TIMING LIGHT

This timing procedure requires that a VOES switch be connected to the HI-4. For racing and early points applications without a VOES switch, you must ground the VOES input (HI-4 green wire) while setting the timing. Connect a timing light to the front cylinder. Set the HI-4 advance trimpot to midrange. Run the engine at 2,400 to 2,500 RPM. Adjust HI-4 position until advance timing mark is centered in the observation hole. Tighten the standoffs and verify that timing has not shifted.

### SETTING PRECISE ADVANCE TIMING FOR RACING USING DIAL BACK TIMING LIGHT

Determine the advance you want at 2,500 RPM. Use a dial-back timing light. Set the amount of advance you want, say 35 degrees, on the dial-back timing light. Connect the dial-back timing light to the front cylinder. If the VOES is used, disconnect the VOES input (HI-4 green

wire) while setting the timing with this procedure. Set the HI-4 advance trimpot full clockwise for maximum advance. Run the engine at 2,500 RPM. Adjust HI-4 position until TDC timing mark is centered in the observation hole. You will now have the amount of advance you dialed into the timing light. Tighten the standoffs and verify that timing has not shifted.

**NOTE: Make sure that your dial-back timing light is compatible with dual fire H-D® engines, otherwise you will get a false reading. Check with the manufacturer of the timing light to be sure.**

## ADVANCE CURVE SETUP

After you have set the timing as explained above, set the HI-4 advance trimpot to desired position. If you run 93 octane gasoline, you can usually leave the trimpot full clockwise for maximum advance and performance without spark knock. High compression engines may require less advance. You should use the Race Only advance curve for high compression engines (make sure you have the correct advance curve DIP switch setting).

## COVER PLATE ASSEMBLY

You can re-use the OE hardware, except use the supplied Crane gasket to provide proper clearance for the HI-4. For models with a riveted outer cover, use the supplied self-threading screws in place of the rivets.

## TROUBLESHOOTING

Did the engine run properly before installation of the HI-4? If not, remove the HI-4, reinstall the OE ignition or another known good unit and then find and correct the original problem. Did the HI-4 function correctly before the problem occurred? If the answer is yes, did you change anything that may have affected it? Try going back to the last setup that worked OK to help isolate the problem.

If the engine will not start, or runs rough or intermittently, use the following checklist steps:

### ENGINE WILL NOT START

1. Check that timing LED lights up when ignition key is first turned on. If not, check for +12 volts on red wire from HI-4.
2. Check that timing LED blinks while engine is cranked. If not, HI-4 may be defective.
3. If the timing LED blinks, but engine will not start, recheck all wire harness connections or replace coil(s).

4. Check for low voltage from a faulty or marginal charging system and battery.

**NOTE: The battery ground on most Harley-Davidsons® is connected to the frame behind the seat. In order to provide a dedicated ground for the high starter current, another cable should be installed from the point on the frame that the battery is already grounded to the starter mounting flange. This cable should be the same diameter as the battery ground cable presently on the bike, and will help prevent damage to your electronic components.**

## CHECKING FOR SPARK

To crank the engine and check for spark, use a KD Tools test plug or H-D® tool HD-26792. These test plugs come with an alligator clip that must be attached to frame or engine ground. Use a length of spark plug wire to connect the test plug to the coil.

**WARNING: Never crank the engine with any spark plug wire disconnected.**

## MISFIRE OR INTERMITTENT OPERATION

Field experience has shown that popping back through the carburetor, misfiring, and intermittent failure (especially after the engine gets hot) are usually not caused by electrical problems within the HI-4. Carburetor problems, fouled spark plugs, coil failure, and loose wire harness connections are the most common culprits. Verify that spiral core or suppression type spark plug wires and resistor spark plugs are being used.

## TACH INOPERATIVE

Damage to the HI-4 circuitry may have occurred if 12 volts was applied to the brown tach wire at any time. The HI-4 tach output is compatible with ground sensing tachs which includes most OE and aftermarket tachs. Some tachs require a high voltage trigger pulse. In this case, you must connect the tach to the Coil- terminal (HI-4 black wire). Note that the tach will read correctly at the rev limit only if it is connected to the brown wire from the HI-4.