

LED HEADLAMP KIT

GENERAL

Kit Number

73390-10A, 67700040A, 67700173

Models

For model fitment information, see the P&A Retail Catalog or the Parts and Accessories section of www.harley-davidson.com (English only).

Additional Parts Required

WARNING

The rider's safety depends upon the correct installation of this kit. Use the appropriate service manual procedures. If the procedure is not within your capabilities or you do not have the correct tools, have a Harley-Davidson dealer perform the installation. Improper installation of this kit could result in death or serious injury. (00333a)

NOTE

This instruction sheet references service manual information. A service manual for your model motorcycle is required for this installation and is available from a Harley-Davidson dealer.

Separate purchase and installation of additional parts or accessories may be required for proper installation of this kit on your model motorcycle. See the P&A Retail Catalog or the Parts and Accessories section of www.harley-davidson.com (English only) for a list of required parts or accessories for your model.

Kit Contents

See Figure 5 and Table 1.

REMOVAL

WARNING

To prevent accidental vehicle start-up, which could cause death or serious injury, disconnect battery cables (negative (-) cable first) before proceeding. (00307a)

WARNING

Disconnect negative (-) battery cable first. If positive (+) cable should contact ground with negative (-) cable connected, the resulting sparks can cause a battery explosion, which could result in death or serious injury. (00049a)

WARNING

To prevent accidental vehicle start-up, which could cause death or serious injury, remove main fuse before proceeding. (00251b)

1. Follow the instructions in the service manual to disconnect the battery cables, negative (1) cable first or remove the main fuse.
2. See the service manual and follow the instructions to replace the headlamp, removing any trim rings and hardware. Save the hardware and trim ring for installation. On black version, use the included black retainer ring.
3. Disconnect the harness and remove the headlamp:
 - a. **2006-2010 FLHTCUSE Models:** Unplug cigar lighter and garage door opener to remove existing jumper harness.
 - b. **All other Models:** Remove existing jumper harness.
4. Remove the mounting ring and mounting ring hardware. Discard the mounting ring and headlamp.

INSTALLATION

WARNING

Connect positive (+) battery cable first. If positive (+) cable should contact ground with negative (-) cable connected, the resulting sparks can cause a battery explosion, which could result in death or serious injury. (00068a)

1. **2014 and later Touring Models:** See the P&A Retail Catalog or the Parts and Accessories section of www.harley-davidson.com (English only) for a list of required parts or accessories for your model.
2. See the service manual and install the new mounting ring.
3. Connect the harness to headlamp:
 - a. **Domestic Models:** See Figure 5. The position lamp connector (6) is not used.
 - b. **HDI Models:** Connect the position lamp connector to the harness connector.
 - c. **2006-2010 FLHTCUSE Models:** Use harness jumper 71628-04 to reconnect the cigar lighter, garage door opener and headlamp.
4. See the service manual and follow the instructions to install the headlamp.

WARNING

After installing seat, pull upward on seat to be sure it is locked in position. While riding, a loose seat can shift causing loss of control, which could result in death or serious injury.

5. Install seat (if removed) according to the instructions in the service manual.

HEADLAMP ALIGNMENT PROCEDURE

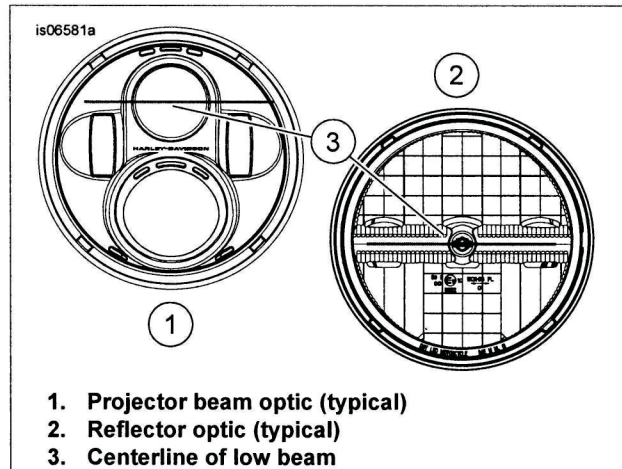

Figure 1. Headlamp Configuration

NOTE

Because of the differences between an LED headlamp and a halogen headlamp, the alignment procedure is performed on both the **low beam** and the **high beam**. Read these instructions thoroughly to properly align the LED headlamp.

1. Verify that front and rear tire inflation pressures are correct and that the suspension is adjusted to the weight of the principal rider. Refer to the owner's manual.
2. Fill fuel tank or add an equal amount of ballast.
3. See Figure 2. Position motorcycle so that front axle is 25 feet (7.6 meters) (3) from wall.

NOTE

As the weight of the rider will compress the suspension slightly, have a person whose weight is approximately the same as that of the principle rider sit on the motorcycle.

4. See Figure 1. With vehicle laden and upright, point the front wheel straight forward at wall and measure the distance from the floor to the center of the **low beam** lens (3). Record this measurement.
5. See Figure 2. Draw a horizontal line on the wall at (5) on the wall that is the same measurement as the measurement recorded in Step 4.
6. Draw a vertical line (2) off of the perpendicular line (1) so that it crosses through the horizontal line drawn in the previous step.
7. If equipped with additional lighting such as passing lamps, verify those lights are OFF during the alignment procedure.

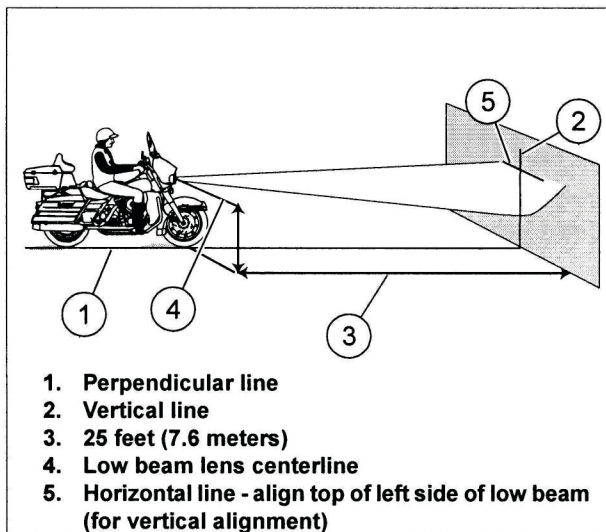

Figure 2. Checking Headlamp Alignment

Alignment of High Beam (Left-to-Right Alignment)

1. Verify that the headlamp lens is perpendicular to the front forks for proper left-to-right alignment.
2. See Figure 3. With vehicle laden and upright, point the front wheel straight forward at wall.
3. Turn on the **high beam** and align the center of the **high beam** hot spot with the intersection of the horizontal and vertical lines (3).

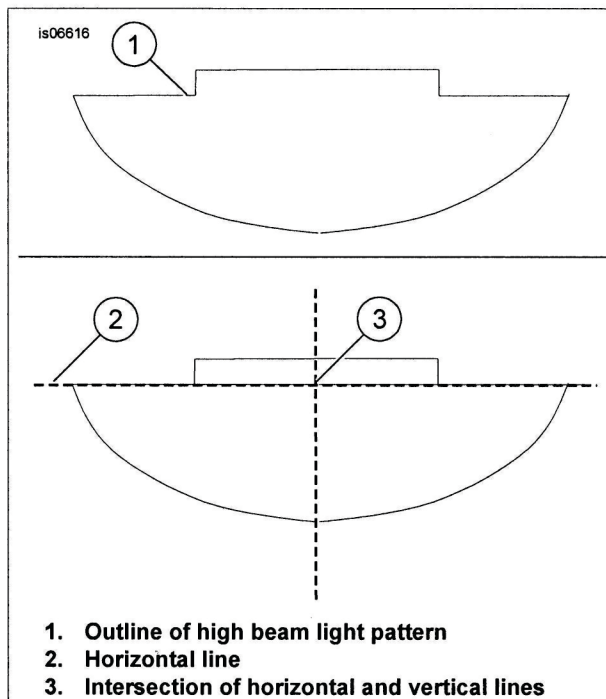

Figure 3. Alignment of Headlamp High Beam

Alignment of Low Beam (Vertical Alignment)

1. See Figure 4. Align the left side of the horizontal line of the **low beam** light pattern (3) with horizontal line (2) drawn on the wall. If necessary, adjust the headlamp position by following the adjustment procedure in the service manual.