

LCD OIL TEMPERATURE/LEVEL DIPSTICK

Part Numbers

Chrome: 40-0890, 40-1284, 40-1285

Black: 40-1286, 40-1287, 40-1288

Dipstick Service Kit (with Replacement Battery): 91800066

Kit Contents

There are no service parts for the LCD assembly or dipstick. A replacement CR 2032 battery (Part No. 66373-06) is available for separate purchase for all oil temperature/level dipsticks.

A Dipstick Service Kit (Part No. 91800066), which includes O-rings, screws and a replacement CR 2032 battery is available for certain models (see Table 1 and Figure 3).

LCD DIPSTICK INSTALLATION

1. Remove the original equipment (OE) dipstick from the filler neck.
2. Non-threaded Dipstick: Lightly oil the O-ring on the new LCD dipstick. Install the dipstick so the display window is: Push the dipstick straight into the filler neck until it seats.
 - a. horizontal,
 - b. readable from left to right,
 - c. with Bar and Shield logo on left (toward the rear).
3. Threaded Dipstick: Lightly oil the O-ring. Screw dipstick into the transmission like the OE dipstick. If the orientation of the display is unsatisfactory when fully seated, refer to Adjusting the Display Angle later in these instructions.

NOTE

To make sure of correct readings, the dipstick **MUST** seat firmly against the flange.

LCD DIPSTICK USE AND CARE

Removing the Dipstick

The dipstick assembly must be removed from the filler neck to add oil or to service the internal battery.

Displaying the Oil Temperature and Level

See Figure 1. Press and release the rubber button on the front face to display:

- temperature of oil in oil tank in degrees Fahrenheit (°F).
- engine oil level.

The display automatically shuts off after about ten seconds.

NOTICE

Do not overfill oil. Doing so can result in oil carryover to the air cleaner leading to equipment damage and/or equipment malfunction.

NOTE

Oil level cannot be accurately measured:

- on a cold engine
- with the motorcycle upright
- with the engine running

On 2000-2004 Softail models with original dipstick, oil level is checked with motorcycle standing upright (NOT leaning on the jiffy stand).

On 2000-later Softail models with LCD oil temperature/level dipstick, oil level inspection must be done with motorcycle on level ground, **LEANING** on the jiffy stand.

For pre-ride oil level inspection:

With the motorcycle on level ground, **LEANING** on the jiffy stand:

- Proper oil level would be as indicated in Figure 1, display 4-8 (bars showing oil level and flashing oil temperature, followed by “COLD OIL” message when engine is cold). **DO NOT ADD OIL** to bring level to the FULL mark on the dipstick of a COLD engine.
- If the oil level indicates as in display 9 (animated level bars, followed by an “888 NO SENSOR” code), the wires inside the dipstick could be disconnected or damaged. Refer to Replacing the Battery later in these instructions to separate the dipstick upper and lower assemblies. If the small plug next to the battery has become dislodged from the receptacle, reconnect it. If a visible wire is damaged, a repair can be attempted. If no damage is visible, the dipstick is damaged internally and needs replacement.

For oil level inspection at operating temperature: Run motorcycle until engine is at normal operating temperature.

Softail models: Idle for 1-2 minutes with the motorcycle in an UPRIGHT position. Turn off engine. Lean on jiffy stand.

Models EXCEPT Softail: Idle for 1-2 minutes with the motorcycle on level ground, **LEANING ON** the jiffy stand. Turn off engine.

- Bubbles in the oil may cause inaccurate readings. Wait two minutes for the oil to settle and for any bubbles to come to the surface.
- Press and release the rubber button on the front face of the LCD oil temperature/level dipstick to display temperature and oil level in the oil tank. Proper oil level would be as indicated in Figure 1, display 11-14.
- If the oil level indicates as shown in display 10 or 15, refer to OIL LEVEL HOT CHECK in the owner’s manual for proper oil fill procedure.
- If the oil level indicates as in display 9 (animated level bars, followed by an “888 NO SENSOR” code), the dipstick is not functioning correctly. Refer to the pre-ride inspection instructions.

Changing the Display Mode

To change the display to read in degrees Centigrade (°C):

- Press and hold in the button for approximately five seconds.
- Release the button.

From then on, pressing and releasing the button displays the temperature in “°C”.

Change back to “°F” display in the same way.

Extended Temperature/Level Display

Press the button twice in rapid sequence to have the display remain on for an extended time. The display will shut off automatically after about two minutes. To shut off the display manually sooner, press the button once

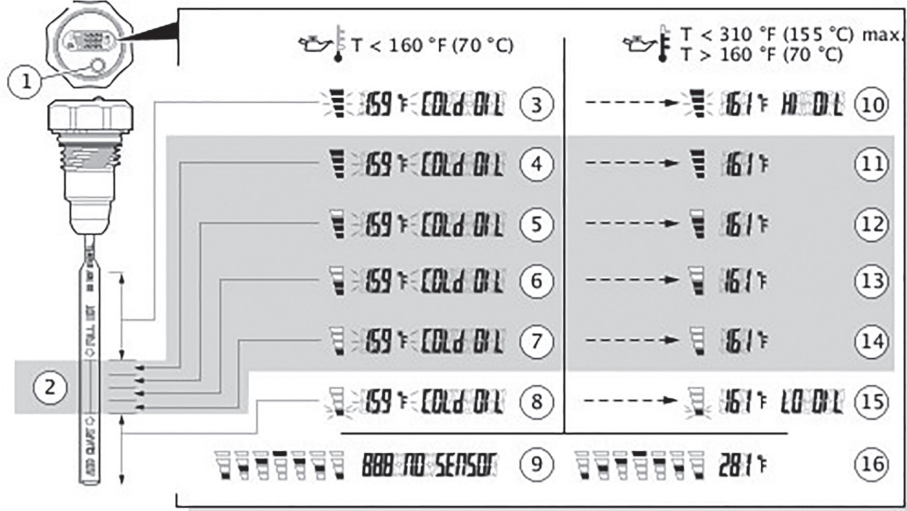

Figure 1. LCD Oil Temperature/Level Dipstick

- 1 Rubber button
- 2 Adequate oil level range, engine at normal operating temperature, vehicle resting on stand, on level ground
- 3 Displayed when oil level is overfull, oil temperature less than 160 °F (70 °C).
- 4 Displayed when oil level is full, oil temperature less than 160 °F (70 °C).
- 5 Displayed when oil level is 0.25 qt (0.24 L) low, oil temperature less than 160 °F (70 °C).
- 6 Displayed when oil level is 0.5 qt (0.47 L) low, oil temperature less than 160 °F (70 °C).
- 7 Displayed when oil level is 0.75 qt (0.71 L) low, oil temperature less than 160 °F (70 °C).
- 8 Displayed when oil level is 1.0 qt (0.95 L) low, oil temperature less than 160 °F (70 °C).
- 9 Displayed when a disconnected or damaged wire is present.
- 10 Displayed when oil level is overfull, oil temperature 160 °F (70 °C) or above.
- 11 Displayed when oil level is full, oil temperature 160 °F (70 °C) or above.
- 12 Displayed when oil level is 0.25 qt (0.24 L) low, oil temperature 160 °F (70 °C) or above.
- 13 Displayed when oil level is 0.5 qt (0.47 L) low, oil temperature 160 °F (70 °C) or above.
- 14 Displayed when oil level is 0.75 qt (0.71 L) low, oil temperature 160 °F (70 °C) or above.
- 15 Displayed when oil level is 1.0 qt (0.95 L) low, oil temperature 160 °F (70 °C) or above.
- 16 Displayed when oil temperature is above 280 °F (138 °C).

Display Errors

An “888 NO SENSOR” error code and animated level bars (Figure 1, display 9) indicates a disconnected or damaged wire.

When the power level of the dipstick battery falls below 2.4 V the LED backlight is disabled, and the battery symbol (see Figure 2) begins to flash.

NOTE

To help prevent failure of the electronics inside, the dipstick does not measure oil level when the oil temperature exceeds 138 °C (280 °F). Animated level bars display, along with the temperature (Figure 1, display 16), up to a maximum reading of 155 °C (310 °F).

The high temperature does not damage the dipstick .

Level measurement readings resume when the oil temperature drops below 138 °C (280 °F).

Figure 2. Battery Symbol

Adjusting the Display Angle

When the LCD oil temperature/level dipstick is first installed and fully seated, the display is best oriented parallel to the vehicle for easy reading. On threaded body dipsticks, if the display is rotated to an unsuitable viewing angle follow these steps:

NOTE

See Figure 3. Be careful when separating the upper display body (A) and lower dipstick assembly (B).

Remove the four small Phillips head screws (2) on the underside of the display body.

While taking care not to strain the wiring, gently pull the lower dipstick assembly out of the upper display body. Carefully separate the upper and lower assemblies.

NOTE

On threaded body models the lower dipstick assembly can be rotated in relation to the upper display body in any of eight positions. Choose the position that orients the display most closely to parallel.

Rotate the lower dipstick assembly to a suitable position. Assemble, taking care not to pinch the wiring or silicone seal ring. Install the four screws. Tighten securely.

Replacing the Battery

A long lasting, replaceable CR 2032 lithium battery powers the LCD oil temperature display. When battery replacement is needed, use only a CR 2032 battery.

A replacement CR 2032 battery (Part No. 66373-06) is available from a dealer. These batteries are also widely available at local battery outlets.

Certain models require purchase of a Dipstick Service Kit (Part No. 91800066), available from a dealer. This Kit includes O-rings, screws and a replacement CR 2032 battery (see Figure 3 and Table 1).

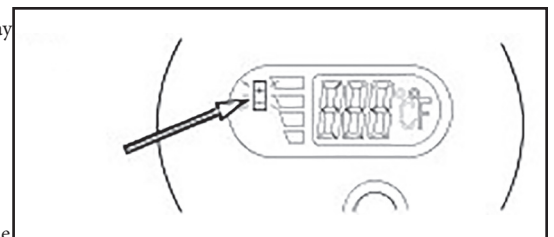

Figure 2. Battery Symbol

NOTICE

Read the following instructions and make sure you fully understand them prior to replacing the battery. If the procedure is not within your capabilities, or you do not have the correct tool, have a dealer replace the battery. Improper installation could result in damage to this product.

NOTE

See Figure 3. Mark the upper display body (A) and lower (B) dipstick components before disassembly, so they can be assembled in the same rotational alignment. Be careful when separating the two components.

Remove the four small Phillips head screws (2) on the underside of the display body.

While taking care not to strain the wiring, gently pull the lower assembly out of the upper display body. Carefully separate the upper and lower assemblies.

Note the battery orientation. Using a mechanic pick or a small screwdriver, carefully insert the tool under the battery (4). Gently pry the battery free and discard it. Insert the new battery as shown. Push the battery down until seated.

NOTE

If present, remove and replace the thin red O-ring (3).

The thin O-ring could stick to either half of the assembly.

Make sure that the existing O-ring is completely removed before installing the new O-ring.

Carefully seat the new thin O-ring on the lower assembly (B) before the halves are reassembled.

Align the lower assembly (B) with the upper body (A). Assemble the two parts in the same rotational orientation as before disassembly. Do not pinch the wiring or thin O-ring. Install the four screws. Tighten securely.

If present, remove and replace the thick O-ring (1) before installing the dipstick. Insert the dipstick into the filler neck.

Check for proper operation by pressing the rubber button on the front face. See LCD Dipstick Use and Care.

Dipstick Service Kit

Table 1. Dipstick Service Kit

Kit	Item	Description (Quantity)
Kit 91800066		
Dipstick Service Kit	1	O-Ring, thick (not required for Softail or 2002-2006 Touring models)
Not sold separately	2	Screw, Phillips head, special (4)
Not sold separately	3	O-Ring, thin (not required for 2004-Later XL Sportster models)
Not sold separately	4	
Battery (CR2032)		66376-06
Items mentioned in text.	A	
Upper display body	B	
Lower dipstick assembly		

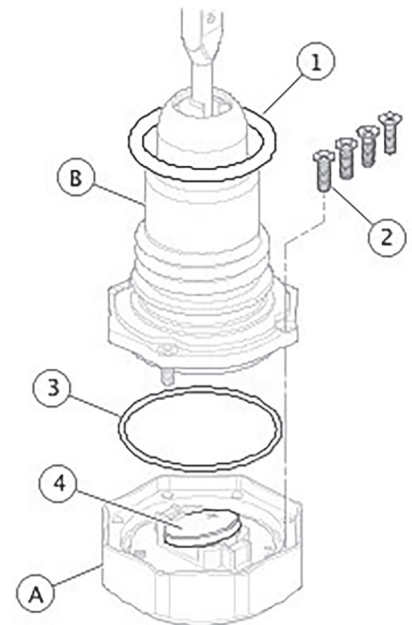

Figure 3. Dipstick Service Kit

Nature of the Liquid Crystal Display (LCD)

Due to the nature of an LCD, the readout does not display oil temperature properly when exposed to extreme temperatures caused by heat transfer from the transmission case or oil tank.

These extremes can occur in stop and go traffic and/or parade duty combined with a high ambient (outside air) temperature. If this situation occurs, DO NOT be alarmed. The LCD has not been damaged, Proper function returns when the LCD reaches a normal operating temperature.

Note also that, after prolonged exposure to direct bright sunlight, some or all of the LCD segments can become visible, giving the appearance of reading improperly without the rubber button having been pressed. This appearance can be overcome by shading the display until the face temperature cools enough to achieve a proper reading.