

SADDLEBAG GUARD KIT VT No. 51-1061 and 51-1062

WARNING

The rider's safety depends upon the correct installation of this kit. If the procedure is not within your capabilities or you do not have the correct tools, have a Harley-Davidson dealer perform the installation. Improper installation of this kit could result in death or serious injury. (00308a)

Kit Contents

See Figure 2 and Table 1.

WARNING

Front and/or rear guard(s) can provide limited leg and cosmetic vehicle protection under unique circumstances. (Fall over while stopped, very slow speed slide.) It is not made or intended to provide protection from bodily injury in a collision with another vehicle or any other object. (00022b)

PREPARATION

NOTE

For vehicles equipped with security siren: Verify that the Hands-Free Fob is present.

REMOVAL

1. See the owner's manual and remove the saddlebags.
2. Remove the seat per the owner's manual. Remove the side covers per the owner's manual.
3. See Figure 1. Remove and retain the 5/16-18 hex screws (3) and lockwashers (4), rubber mount (1) and bracket (2) securing the muffler to the saddlebag support tube (5) on one side of the vehicle.
4. Remove the 5/16-18 TORX® screw (6) and flange nut (7) retaining the rear of the saddlebag support tube to the saddlebag support casting (10) and fender rear support bracket. Retain the screw for later assembly. The nut can be recycled or properly disposed of.

- | | |
|----|--|
| 1 | Rubber exhaust mount |
| 2 | Exhaust mounting bracket |
| 3 | Hex screw (2), 5/16-18 x 1/2 in (13 mm) |
| 4 | Split lockwasher (2) |
| 5 | Saddlebag support |
| 6 | TORX screw, self-tap, 5/16-18 x 1 in (25 mm) |
| 7 | Flange nut |
| 8 | TORX screw, 3/8-16 x 7/8 in (22 mm) |
| 9 | Lock nut |
| 10 | Saddlebag support casting |
| 11 | TORX screw, 3/8-16 x 2-1/2 in (64 mm) |
| 12 | Lock nut |

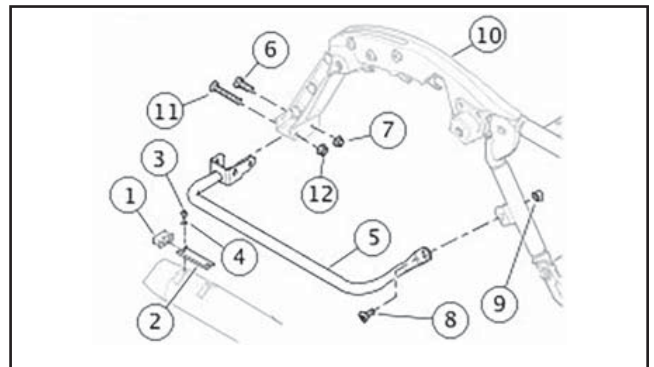

Figure 1. Remove Saddlebag Support (Right Side Shown)

5. Remove the 3/8-16 TORX screw (8) and locknut (9) retaining the front of the saddlebag support to the frame down tube. Retain the screw for later assembly. The locknut can be recycled or properly disposed of.
6. Remove the 3/8-16 TORX screw (11) and flange nut (12) retaining the rear of the saddlebag support tube to the support casting (10). Retain the screw for later assembly. The nut can be recycled or properly disposed of.

INSTALLATION

1. See Figure 2. Loosely assemble the U-bracket on the rear of the new saddlebag support tube (5 or 6) to the saddlebag support casting (G) with the 3/8-16 x 64 mm (2½ in) long TORX screw (H, removed earlier) and flange nut (4) from the kit.
2. Get the correct front saddlebag guard (1 or 2), 3/8-16 x 22 mm (in) long TORX screw (3), flange nut (4), 1/4-20 x 32 mm (1¼ in) long hex socket screw (7) and locknut (8) from the kit.
3. Slide the short tube on the guard onto the front of the saddlebag support tube.
4. Loosely install the guard to the vehicle upper frame tube with the 3/8-16 x 22 mm (in) long TORX screw (3). Loosely install the guard to the frame down tube with the 3/8-16 x 22 mm (in) long TORX screw (F, removed earlier) and the flange nut (4).
5. Align the holes in the saddlebag guard short tube and saddlebag support tube, and insert the 1/4-20 x 32 mm (1¼ in) long hex socket head screw (7) through the hole. Install the locknut (8) onto the screw threads, but do not fully tighten.
6. Loosely assemble the muffler to the saddlebag support rail with the 5/16-18 x 13 mm (½ in) long flanged hex head screws (C) and lockwashers (D), rubber mount (A) and bracket (B) removed earlier.

NOTE

For models except FLHX/S: Insert screw (E), from the rear, through the fender rear support bracket, saddlebag support casting (G) and inboard hole of the saddlebag support tube as shown in Figure 2.

For FLHX/S models: Insert screw (E), from the front, through the inboard hole of the saddlebag support tube, saddlebag support casting (G) and fender rear support bracket as shown in the Figure 2 inset.

7. Install the 5/16-18 x 25 mm (1 in) long TORX screw (E, removed earlier) and flange nut (9) retaining the rear of the saddlebag support tube to the saddlebag support casting (G) and fender rear support bracket. Tighten to 20.3–27.1 N·m (15–20 lb.ft.).
8. Tighten the 3/8-16 TORX screw (H) and flange nut (4) to 40.7–50.2 N·m (30–37 lb.ft.).

9. Tighten the 3/8-16 TORX screw (3) at the upper frame tube to 43.4–48.8 N·m (32–36 lb.ft.).
 10. Tighten the 3/8-16 TORX screw (F) and nut (4) at the frame downtube to 43.4–48.8 N·m (32–36 lb.ft.).
 11. Tighten the 3/8-16 hex socket screw (7) and locknut (8) at the front of the saddlebag support tube to 7.9–11.3 N·m (70–100 in.lb.).
 12. Tighten the hex screws (C) securing the muffler to 10.8–16.3 N·m (96–144 in.lb.).
 13. Repeat the removal and installation steps on the opposite side of the vehicle.
- WARNING**
After installing seat, pull upward on seat to be sure it is locked in position. While riding, a loose seat can shift causing loss of control, which could result in death or serious injury. (00070b)
14. Refer to the owner's manual and install the seat. Install the side covers.
 15. Install the saddlebags per the owner's manual.

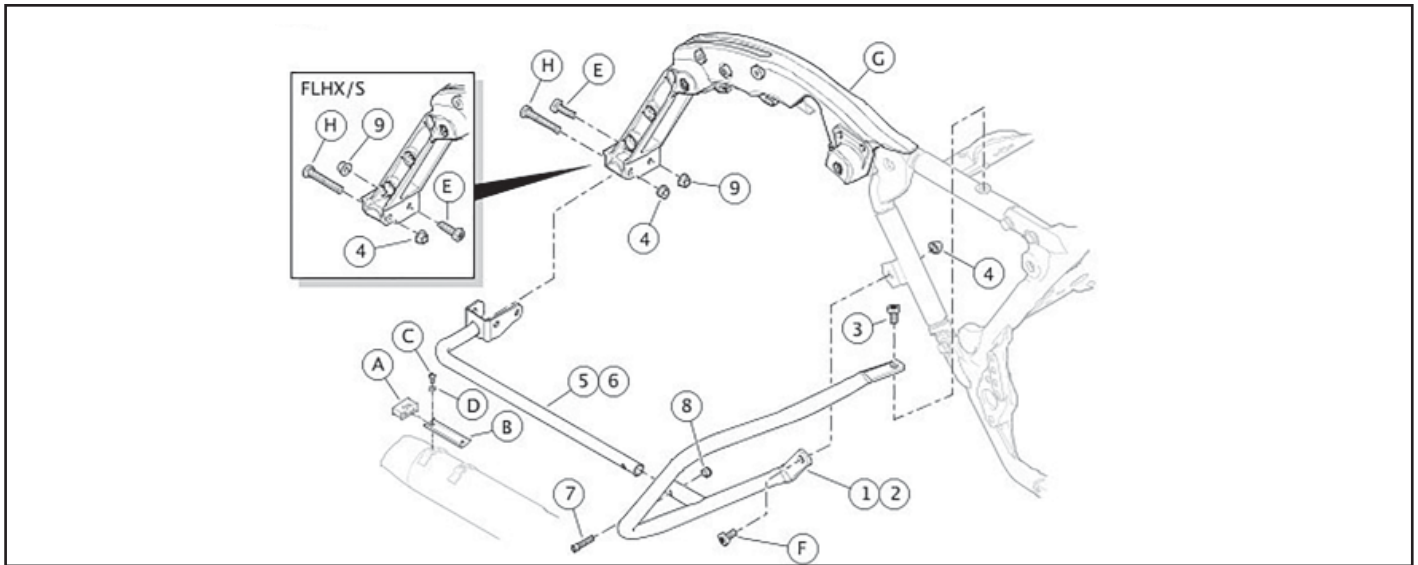

SERVICE PARTS

Figure 2. Service Parts, Saddlebag Guard Kits

SERVICE PARTS

Table 1. Service Parts

Kit	Item	Description (Quantity)
51-1061	1	Saddlebag Guard (Chrome)
	2	Saddlebag guard, front, Chrome (right side-shown)
		Saddlebag guard, front, Chrome (left side-not shown)
		Saddlebag Guard (Gloss Black)
		Saddlebag guard, front, Gloss Black (right side-shown)
		Saddlebag guard, front, Gloss Black (left side-not shown)

Parts common to both kits

3	Screw, TORX button head, 3/8-16 x 22 mm (in) long (2)
4	Flanged locknut, 3/8-16 (4)
5	Tube assembly, lower, Gloss Black (right side-shown)
6	Tube assembly, lower, Gloss Black (left side-not shown)
7	Cap screw, hex socket head, 1/4-20 x 32 mm (1¼ in) long (2)
8	Hex locknut, 1/4-20, with nylon insert (2)
9	Flanged locknut, 5/16-18 (2)

Items mentioned in text, but not included in kit:

A	Original equipment (OE) rubber exhaust mount (2)
B	OE exhaust mounting bracket (2)
C	OE hex head screw, 5/16-18 x 13 mm (½ in) long (4)
D	OE split lockwasher (4)
E	OE TORX head self-tapping screw, 5/16-18 x 25 mm (1 in) long (2)
F	OE TORX head screw, 3/8-16 x 22 mm (in) long (2)
G	OE saddlebag support casting (right side shown)
H	OE TORX head screw, 3/8-16 x 64 mm (2½ in) long (2)