

CHOPPED ENGINE GUARD

VT No. 51-1065, 51-1070, 51-1071, 51-1072

WARNING

Rider and passenger safety depend upon the correct installation of this kit. Use the appropriate service manual procedures. If the procedure is not within your capabilities or you do not have the correct tools, have a dealer perform the installation. Improper installation of this kit could result in death or serious injury.

WARNING

Front and/or rear guard(s) can provide limited leg and cosmetic vehicle protection under unique circumstances. (Fall over while stopped, very slow speed slide.) It is not made or intended to provide protection from bodily injury in a collision with another vehicle or any other object.

NOTE

This instruction sheet references service manual information. A service manual for your model motorcycle is required for this installation.

REMOVAL

VT No. 51-1065, 51-1070

FLTR Models Only

Remove the outer fairing following the instructions in the service manual.

See Figure 1. Remove the two screws (1) and mounting clamp (2) from the fairing support (5).

Remove and retain the screw (3) and washer (4) that attach the stock fairing support to the motorcycle. Remove the stock fairing support. Repeat on opposite side.

ALL Models

Remove and retain the two screws that attach the bottom of the stock engine guard to the motorcycle frame.

Remove and discard the hex socket screw and washer holding the top of the guard. Remove the engine guard from the frame, taking care not to scratch the finish on the motorcycle.

Install Engine Guard

1. See Figure 2. Hold the engine guard in position, and loosely fasten the top of the guard with the new hex socket screws (2) and flat washers (3) from the kit.

2016 and earlier: Install additional flat washers between engine guard and frame.

2. Install the bottom brackets to the motorcycle frame with the two TORX screws (1), removed earlier.

3. Tighten the top mount screws to 10.8–12.2 N·m (96–108 in-lbs) and the bottom two mounts screws to 20.3–27.1 N·m (15–20 ft-lbs).

Install Fairing Support Assembly (FLTR Models Only)

1. See Figure 3. Hold the fairing support assembly in position, and loosely fasten the mid fairing support mount with the 1/4-20 x 3/4" and 5/16 - 18 x 1" hex socket screws (2, 8), flat washers 1/4" and 5/16" (3, 7) and nut (9) 1/4 x 20.

2. Install the side brackets to the motorcycle with the two screws (5) and washers (6) removed earlier.

3. Tighten upper mid fairing mount screw.

Torque: 21.6–24.4 N·m (16–18 ft-lbs) Mounting screw

4. Tighten lower mid fairing mount screw.

Torque: 5.4–6.7 N·m (48–60 in-lbs) Mounting screws

5. Tighten two side mounts.

Torque: 10.8–12.2 N·m (96–108 in-lbs) Mounting screw

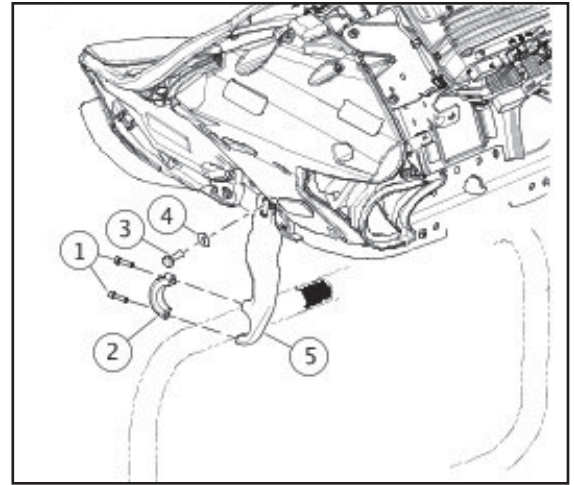

- 1 Screw (2)
- 2 Mounting clamp
- 3 Screw
- 4 Washer
- 5 Fairing support

Figure 1. Remove Engine Guard

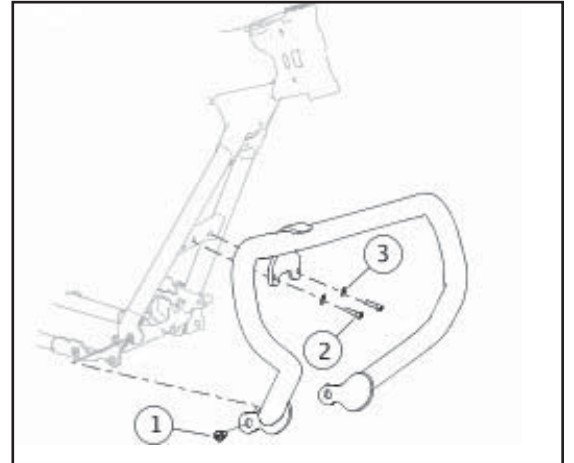

- 1 Screw (2)
- 2 Screw (2)
- 3 Washer (2)

Figure 2. Install Engine Guard

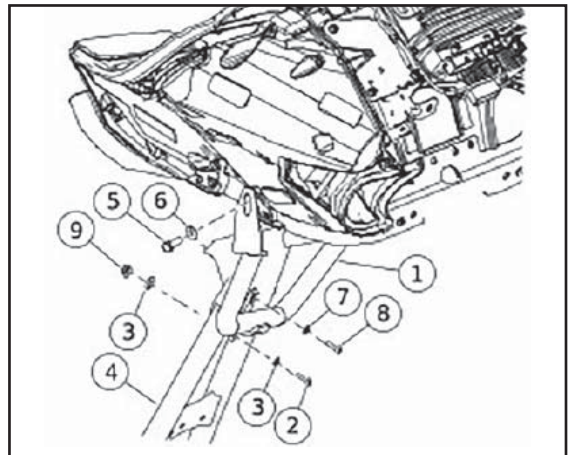

- 1 Fairing support assembly
- 2 Screw (2)
- 3 Washer (3)
- 4 Frame
- 5 Screw
- 6 Washer
- 7 Washer
- 8 Screw
- 9 Nut

Figure 3. Install Fairing Support

Item	Description (Quantity)	Part Number
1	Fairing Support Assembly (51-1071& 51-1072)	
2	Engine Guard Assembly	
3	Screw (2) 1/4 - 20 x 1 1/4 Socket Head	37-8304
4	Washer (51-1071& 51-1072)	8167-12
5	1/4 Flatwasher	8166-12
6	1/4-20 Nut (51-1071& 51-1072)	37-8119
7	5/16-18 x 1 Screw (51-1071& 51-1072)	37-8312
8	1/4-20 x 3/4 Screw (51-1071& 51-1072)	37-8301
Items mentioned in text, but not included in kit:		
A	Screw	
B	Washer	
C	Screw	

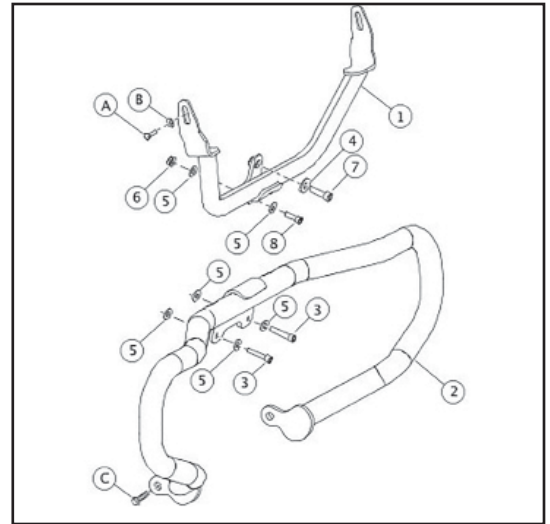

Figure 4. Service Parts: Engine Guard Kit