



AGM Battery

- Ready to Install
- Completely Sealed
- Lock Bonded Plates
- SS Terminal Bolts
- Maintenance Free
- Exact fit



AGM Battery. The “Absorbed Glass Mat” Technology provides higher cold cranking amps, better rechargeability with longer overall life. Batteries are fully sealed for trouble free service in a black case. Available in OE or VT brand. **Note: 1998 and earlier FX models,** require battery side cover, VT No. 42-0770 and a top cover, VT No. 42-0785 for FXD models.

VT No.	OE	OEM	Years/Models
53-0547	53-0534	65991-82B 65991-75C	1973-94 FX-FXR 1984-90 FXST-FLST 1999-2000 FXR
53-0585	—	65991-75	1973-84 FXE
53-0546	53-0535	65989-97A	1997-up FXD, FXST, FLST
53-0789	—	Dry	1997-up FXD, FXST, FLST
—	53-0536	66010-82B	1980-96 FLHR-FLHT-FLT
53-0550	53-0537	66010-97A	1997-up FLHR-FLHT-FLTR
53-0545	53-0538	65989-90B	1991-96 FXD-FXST-FLST (Note: OE 1/2" Thicker)
—	53-0785	—	2001-up V-Rod

Note: AGM Batteries may require charging before installation.



Battery Hydro-meter is a great tester for cycle batteries because of its small size.

VT No. 16-0864



“Activator” Battery Filler attaches to any standard acid pack tube. Positive thumb release valve absolutely controls acid flow. No acid spills, burns or holes in clothing.

VT No. 16-0037



Battery Acid Catch Tank attaches to battery vent tube to collect excess acid to protect the frame and lower rear fender parts.

VT No. 16-1739

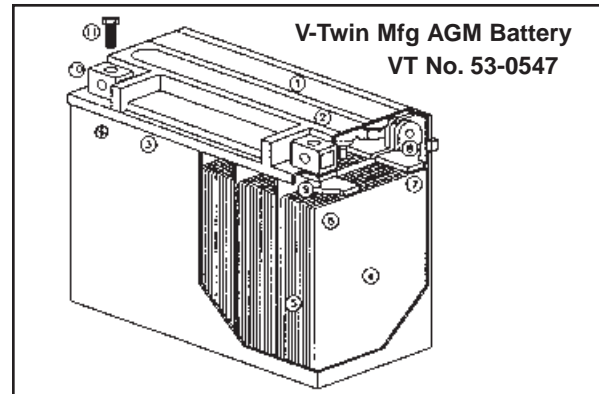

1. Unique vent system minimizes leakage.
2. Completely sealed maintenance free design eliminates acid spills and corrosion damage.
3. Bonded cover prevents electrolyte leakage and improves dependability.
4. Precise volume of demineralized electrolyte means no excess acid and improved life.
5. Positive AGM plate separators ensure long life and improved performance.
6. Durable AGM plates direct maximum cranking amps to terminals for quick starts.
7. Heavy top lead lugs provide improved adhesion to the plates for vibration resistance and long life.
8. Large diameter partition connections direct more power to the terminals.
9. Sturdy diameter bushings resist vibration damage and acid leakage which causes terminal corrosion.
10. Durable two position terminals.
11. Stainless steel terminal screws.



Battery Terminal Hardware Kit includes pieces to simplify battery installations on FXE and late XL models.

VT No. 32-0235



In-Line Fuse Holder has 6" long wire leads.

VT No.	Type
32-0410	Fuse
32-8946	ATC Type