

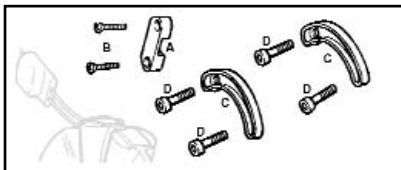

Alternator Stator

BIG TWIN

Stators replace stock units for models listed in molded (M) or unmolded (U) type.		
VT No.	Brand	Type
1981-88 Big Twin, Replaces 29965-81, 22 Amp		
32-0602	Volt Tech	M
32-8081	Volt Tech	U
32-9042	Accel	U
32-9041	Accel	M
1989-99 FXST, FLST; 1989-94 FLT, 1989-94 FXR, 1991-98 Dyna, Replaces 29970-88C, 32 Amp		
32-8083	V-Twin	U
32-8038	V-Twin	U
32-9045	Accel	U
32-0952	Plug Only	
1995-up FLT, Replaces 29969-95, 38 Amp, EFI		
32-0454	Volt Tech	U
1997-98 FLT, Replaces 29987-97		
32-0489	Volt Tech	U
32-9148	Accel	U
1999-01 FLT, FLHR Replaces 29987-99A		
32-0463	Volt Tech	U
2002-05 FLT, EFI, Carb, Replaces 29987-02,		
32-0470	OE	U
32-0872	Volt Tech	U
32-9350	Accel	U
2000 FXST/FLST, 1999-03 Dyna, Replaces 29951-99		
32-0464	Volt Tech	U
32-9145	Accel	U
2001-06 FXST/FLST, 2004-06 Dyna, Replaces 30017-01		
32-0529	Volt Tech	U
32-9146	Accel	U
2007 FLST-FXST, 2007 Dyna, Replaces 30017-07		
32-0868	Volt Tech	U
32-9147	Accel	U
2008-up FXST, Replaces 30017-08		
32-0953	Volt Tech	U
2006-up FLT, Replaces 29987-06		
32-0948	Volt Tech	U
32-9351	Accel	U
2008 FXST-FLST-Dyna, Replaces 30017-08		
32-0953		U



Stator Assembly Kit for Big Twins 1970-86 includes (2) 29988-73 locks, (1) 29954-71 retainer, (4) 2653 screws, (2) 2216W screws.

VT No.	#	OEM	Item
32-0598		Kit	Complete, all
32-0604	A	29954-71	Nylon Retainer, 10 pk.
32-0603	B	2216W	Screw, 10 pk.
37-8812	C	29988-73	Lock Plate, 10 pk.
37-8811	D	2653	Screw, Fillister, 7/8"
37-9003	D	2712	Screw, w/Lock Patch, 7/8"
37-9126		2720	Screw, w/Lock Patch, 1"

Deutsch Connector Sets

VT No.	Fits
32-1854	Stator (32-0529)
32-1855	Regulator (32-0898)

Warranty
All Electrical Components sold as individual pieces or in kits are covered under our warranty "Replacement Only" Provision. All electrical related item part numbers begin with a 32 prefix. No credit will be issued for these items as they are exchange only.



Alternator Rotor

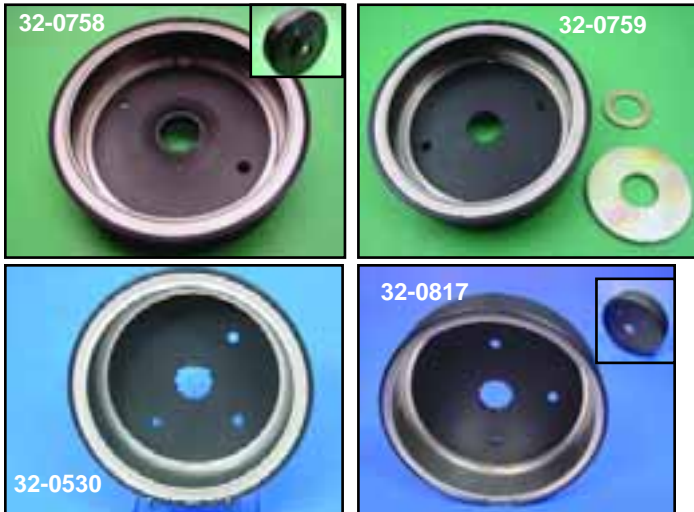

Volt Tech Big Twin Alternator Rotors feature vibration proof magnet construction, as magnets are held in place by stainless steel non-magnetic insert for durability. ***Note:** Built in spacer in spline area.

VT No.	Year	Model
32-0758*	1970-90	ST-FX
32-0759	1981-00	ST-FX
32-0530	1995-05	FLT
	2001-06	ST
32-0817	2006-07	FLT
32-0870	2008-up	ST



45 Amp Rotor Only will convert system to 45 amp using stock stator. The V-Tech rotor features sealed magnets by a stainless insert. Replaces 29999-97. The 1.5" wide rotors fit 1999-05 Big Twins.

VT No.	Type
32-8926	V-Twin
32-0746	VTech



Motor Shaft Spacer features built in seal flange to give added support for alternator rotor.
VT No. 10-0948



Big Twin Alternator Rotor Puller uses the two threaded holes in rotor to allow removal of rotor.
VT No. 16-0693



Big Twin Alternator Rotor features OE type with magnetic inserts installed. 22/32 amp.

VT No.	OEM	Item/Fits
32-7796	29957-81B	Rotor, 1982-2000 FXST/FLST, 1982-94 FLT1982-up FXR, FXD
32-0830	29981-95	1995-05 FLT
32-0939*	40356-06B	2006-up FXD, Set
32-0951	—	2006-up FXD, Rotor
32-0941	—	2008-up FLT

***Note:** Includes stator.



Rotor Shim Kit for installing a 32 amp stator on all 1970-88 Big Twins. Replaces stock rotor shims and provides proper rotor to stator alignment while keeping primary chain alignment.

VT No. 10-6120

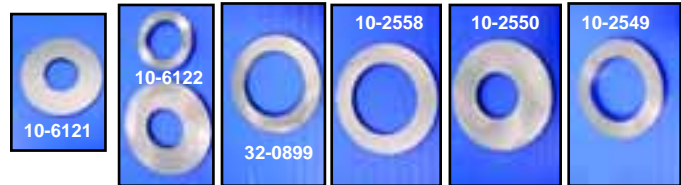

Rotor Shims.

VT No.	OEM	Type	Year
10-6121	Special	Large Spacer	—
10-6122	Special	Large/Small Spacer Kit	—
32-0899	29923-01A	Small Spacer	2001-up
10-2558	29961-85	Small Spacer	1985-90
10-2550	29960-85	Large Spacer	1985-up
10-2549	29960-91	Small Spacer	1991-up
12-1160	603	Alt Roll Pin	1991-up



Order Spacer and Shims separately.

VT No.	OEM	Year	Size	Item
10-0427	24002-70	1970-up		Spacer
Set of 6	24032-70	1970-up	.060	Shim
	24033-70	1970-up	.090	Shim
	24034-70	1970-up	.120	Shim
	24035-70	1970-up	.150	Shim
	24036-70	1970-up	.180	Shim
	24037-70	1970-up	.210	Shim
10-2549	Special	1970-up	.250	Shim



Alternator Kit

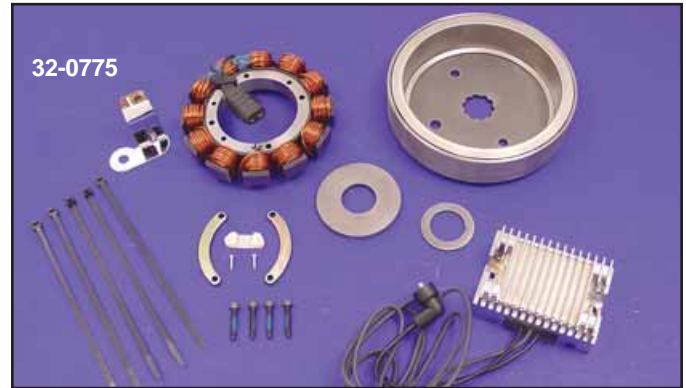

Big Twin Stator Kit features all components including stator, rotor, black solid state regulator, plug retainer and mount kit.
VT No. Type Fits
32-7500 22 Amp 1984-88
32-8927* 32 Amp 1984-88 FLT-FXR and 1989-99 All Big Twins
 *Note: Features unmolded stator.

"Volt Tech" Alternator Kit fits 1984-up Big Twins includes stator, rotor with stainless liner "to seal magnets in place" chrome regulator and mount kit.
VT No. Fits Amp
32-0775 1984-88 FLT-FXR 32
 1989-99 All BT
32-7807 As Above with reinforced rotor splines (A)

Alternator Sealing Ring Service



Moto Shop Alternator Sealing Ring Replacement Service. Ship in 1970-up left hand case with damaged O-Ring lip and we will machine out and replace with new steel sealing ring.
VT No. 60-0164



Big Twin Alternator Rotor Puller uses the two threaded holes in rotor to allow w removal of rotor.
VT No. 16-0693



Big Twin Alternator Rotor Puller uses the sprocket shaft end to center and the two threaded holes in rotor to allow removal of rotor.
VT No. 16-1054



Trock Crankcase Repair Fixture. A precision machined cast iron fixture that allows BT left hand crankcase o-ring seal area to be machined out so new sealing lip ring can be installed. Sealing ring is manufactured from ductile iron and must be loctited in place.
VT No. Item
16-0691 Fixture
16-0692 Sealing Ring
60-0164 Machine & Install Case for sealing



Charging Systems for Touring



Alternator Kit for FLT models include rotor stator and hardware. Use 32-8926 rotor only with 32-7780 kit, to produce 45 amp output.

VT No.	OEM	Amp	Year/Model	Type
32-0375	3 Phase	38	1984-99 BT	Carb
32-7776	29982-81	22	1983-88 BT	Carb
32-0775	29985-87	32	1984-88 FLT-FXR 1989-99 BT	Carb
32-7775	29985-87	32	1983-98 BT	Carb
32-7780	29921-95	38	1995-98 BT	EFI

VT No.	OEM	Amp	Year/Model	Type
32-8975		45	1997-98 BT	EFI/Carb
32-8943		38	1991-96 BT	Carb
32-0373	3 Phase	38	1995-05 BT	Carb
32-8944		45	1991-96 BT	Carb(CE)
32-0994		45	1991-96 BT	Carb
32-8210		45	1997-99 BT	EFI
32-8211		38	1997-99 BT	Carb
32-8212		45	1999-03 BT	EFI
32-0871		45	1999-05 BT	EFI/Carb



45 Amp Rotor Only fits 1999-05 Big Twins for upgrade.

VT No.	Brand
32-8926	V-Twin
32-0746	V-Tech

*Note: Rotor can only be used with VT No. 32-7780 kit to upgrade kit to 45 amps.



Fuse Kit use with 38 amp stator kits, replaces 72372-95.

VT No. 32-9257

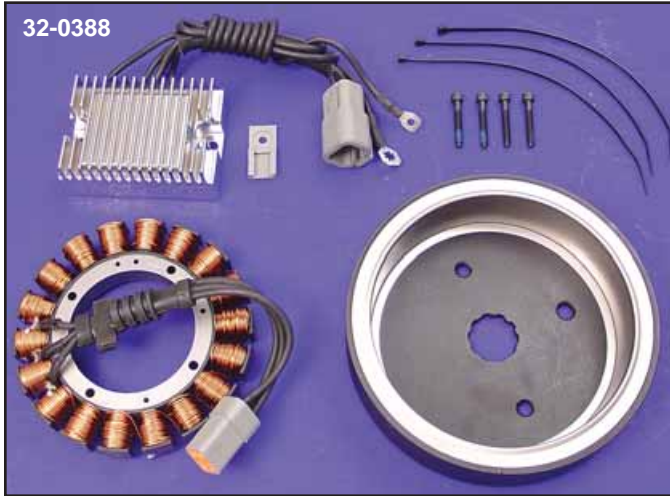

VOLT **VT** TECH **Charging Systems**

VT No. 32-0375

38 Amp ST 3 Phase Alternator Kit features sealed rotor, stator and regulator. Features Deutch connectors and enclosed rare earth magnet rotor.

VT No.	Year	Model
32-0375	1990-99	FX-FL
	1970-99	FX-FL

3 Phase offers better low and high speed output, delivering a smoother charge to the battery.

V-Twin developed the first charging system kits in 1986

38 Amp ST 3 Phase Alternator Kit features sealed rotor, stator, regulator and bracket. All feature Deutsch connectors.

VT No. Fits

- 32-0388** 1999-03 FXD/2000 ST
- 32-0373** 2001-up FLST-FXST, 1995-05 FLT
- 32-0375** 1984-99 FLST-FXST, 1991-98 FXD
1984-94 FXR, FLT
- 32-0378** Regulator for 32-0375

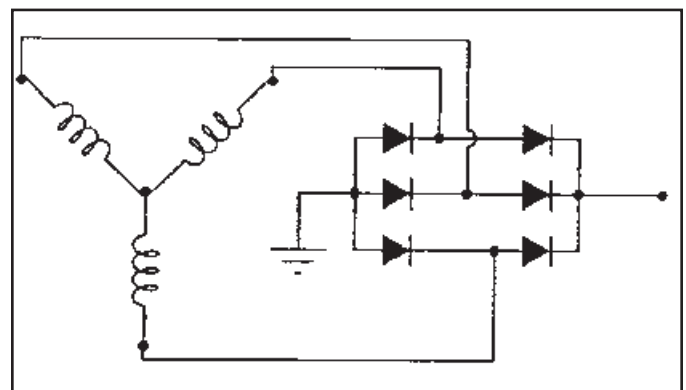

Some basic factoids about **3 Phase**...Most of the electric power in the world is **3 Phase**. The concept was originally conceived by Nikola Tesla and was proven that **3 Phase** was far superior to single phase power. **3 Phase** power is typically 150% more efficient than single phase in the same power range. In a single phase unit the power falls to zero three times during each cycle in **3 Phase** it never drops to zero. The power deliver to the load is the same at any instant. Also, in **3 Phase** the conductors need only be 75% the size of conductors for single phase for the same power output. Therefore a **3 Phase** system provides more current delivery for EFI and other electrical accessories, provide more charging power for increased battery life and easier starting. Not really much more complicated than single phase but much more efficient!!