

VT No. 19-0014
BIG TWIN COMPENSATOR

Models

FLST	2006-17
FLT	2007-16
FLH	2007-13
FLHXXX	2009-13
FXST	2006-17
FXD	2006-17

Original equipment on 2014-17 Dyna, Softail and 2014-16 Touring models

Kit includes the following: Shaft Extension, Sliding Cam, Compensating Sprocket, Thrust Washers, Thrust Bearing, Sprocket Retainer, Torx screw. Also Includes two oil deflectors. One for Touring models, and the other for both Dyna & Softail models, and Retainer Clip.

All models will require **VT No.13-0871**, Compensator Sprocket Spring Pack Kit.

Some models will require two 0.031 thick shims, **VT No. 12-0001**; which will also require a separate purchase.

All models will require Installation Adhesive Kit OEM# 11100088

Kit can also be used to upgrade 2006-11 FXST, FLST, FXD; 2007-13 FLH, & FLT but requires separate purchase of parts noted below.

•2006-11 FXD, 2007-11 FLST, FXST; 2007-10 FLT, and 2009-10 FLHXXX models require the use of a Volt Tech Alternator Rotor, **VT No. 32-0870**. (except 2008-2009 FXCW, 2008-11 FXCWC, 2009 FXSTSSE3, 2010 FXSTSE, 2011 FXSTSE2)

•2006 FXD models will also require the use of a Volt Tech Unmolded 50 Amp 3 Phase, Alternator Stator: **VT No. 32-0868** and Volt Tech Alternator Rotor: **VT No. 32-0870**.

•2006-2011 FXST, FLST and FXD models will also require the use of a Softail/Dyna Oil Deflector OEM# 62700064; Rib Retention Clip (1 required) OEM# 12200065; Installation Adhesive Kit OEM# 11100088 and 0.031" thick shims, (2 required) **VT No. 12-0001**

•2007-2010 FLT, FLH; & 2009-2010 FLHXXX will also require the use of a Touring Oil Deflector OEM# 62700063; Rib Retention Clips (1 required) OEM# 12200065; Installation Adhesive Kit OEM# 11100088 and 0.031 thick shims, (2 required) **VT No. 12-0001**

Additional Parts Required where Required:

Note: A new primary cover gasket must be ordered separately for the proper installation of this kit.

Suggested Parts:

- **VT No. 32-0868** Stator (if required)
- **VT No. 32-0870** Rotor (if required)
- **VT No. 12-0001** 0.031" thick Shims
- **VT No. 15-1547** V-Twin Primary Cover Gasket (2007-16 FLT; 2009-13 FLHXXX)
- **VT No. 15-1510** V-Twin Primary Cover Gasket (2006-17 FXD; FLST 2007-17; FXST 2007-17)
- **VT No. 15-0404** V-Twin Primary Cover Gasket (FLST 2006; FXST 2006)
- OEM# 62700064 Softail/Dyna Oil Deflector
- OEM# 63700063 Touring Oil Deflector Kit
- OEM# 12200065 Rib Retaining Clip
- OEM# 11100088 Installation Adhesive Kit

Suggested Parts:

- **VT No.16-0650** Primary Drive Locking Tool
- **VT No. 16-1669** Compensator Bolt Torx Socket

INSTALLATION

To prevent accidental vehicle start-up, which could cause death or serious injury, disconnect battery cables (negative (-) cable first) before proceeding.

1. Clean primary cover with PJ-1 or equivalent. Wipe the deflector installation area with rubbing alcohol to remove residue. Allow to dry completely.

2. Test fit the appropriate oil deflector included with kit to the cleaned primary cover:

- a. Part No. 62700063 for Touring Models
- b. Part No. 62700064 for Softail or Dyna Models

3. See Figure 2. Place oil deflector (cover side up) on a clean protected surface.

Apply adhesive:

- a. Apply adhesive to the perimeter of the part.
- b. Create an "X" pattern across the part.
- c. Apply adhesive to the sides that contact the primary cover.

4. and press firmly into place. Slide deflector into position. See Figure 3. Carefully position deflector in primary cover DO NOT lift.

5. Install retention clip (not included with the kit) over oil deflector rib and the adjacent aluminum rib as shown.

6. See Figure 4. Protect the outside surface of the primary cover to avoid damage. Secure the oil deflector in place using a C-clamp. Allow approximately 30 minutes before handling.

7. 2006-2011 Dyna, 2007-2011 Softail (except 2008-2009 FXCW, 2008-2011 FXCWC, 2009 FXSTSSE3, 2010 FXSTSE and 2011 FXSTSE2) and 2007-2010 Touring models: See Figure 7. Install the new alternator rotor (A) to the engine compensating sprocket shaft per service manual instructions.

8. See Figure 7. Apply a thin layer of primary chaincase oil to the sliding cam (5) splines and the outer splines of shaft extension (4). Install shaft extension with the flat side against alternator rotor.

9. Install two shims (14) onto shaft extension, if required (not included).

NOTE

Make sure shims (14) do not fall between shaft extension and alternator rotor.

10. Remove the shipping retainer from the spring pack not included. Without disturbing the order, install the spring pack onto shaft extension with the two large disc springs (1) against the shim. The outer diameters of the springs must contact each other as shown in Figure 5.

11. Install the sliding cam (5) with the flat face contacting the small disc spring. Lubricate the sliding cam ramps with primary chaincase oil.

NOTES

- The compensating sprocket (6) is installed with the text "this side out" facing outward.
- Clutch hub mainshaft nut has left-hand threads. Turn counterclockwise to install.
- The primary chain, compensating sprocket and clutch assembly must be installed as an assembly.

12. Place the drive components (primary chain, compensating sprocket and clutch assembly) into position. A slight rotation of the chain drive aids installation onto the splines.

13. Clean and prime threads of clutch hub mainshaft nut. Apply two drops of LOCTITE 262 HIGH STRENGTH THREAD- LOCKER AND SEALANT (red) to the threads. Start nut onto mainshaft. Hand-tighten.

NOTES

When installing screw (10), make sure that the disc springs are properly aligned

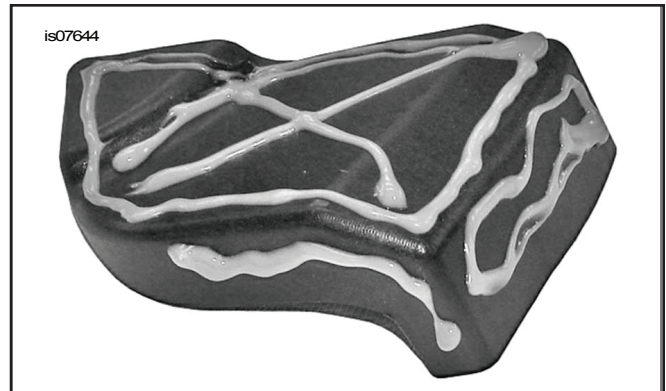

Figure 2.

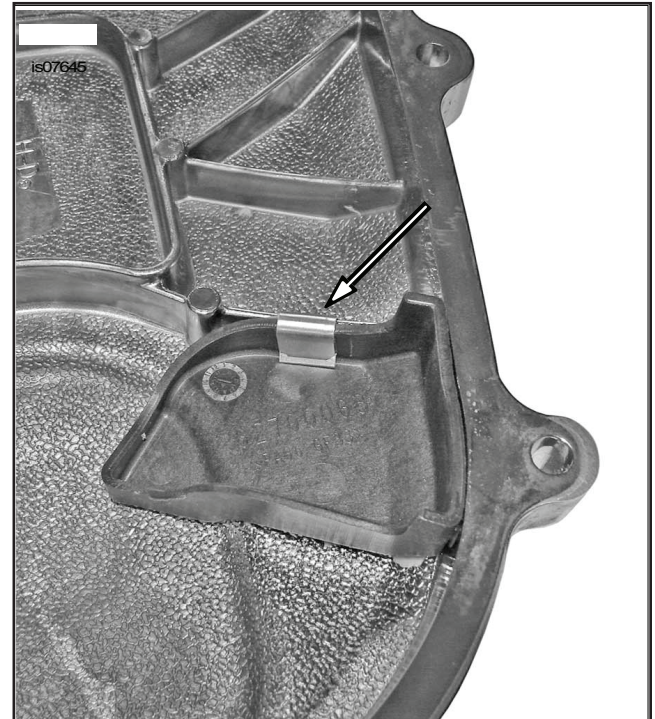

Figure 3. Install Deflector and Retaining Clip, not included in kit

and that the spring nearest the rotor assembly has not slipped between the extension and rotor hub.

14. Lightly lubricate thrust bearing (8) with a thin layer of primary chaincase oil. Install thrust washer (7), bearing (8), thrust washer (7), retainer (9) and screw (10). Hand tighten.

Note: The compensating sprocket screw is a T70 Socket Bit VT No. 16-1669 or equivalent

15. See Figure 6. Place the PRIMARY DRIVE LOCKING TOOL between the teeth of the engine and clutch sprockets as shown. **NOTE** The compensating sprocket screw is a T70 drive. Use T70 SOCKET BIT Snap-on STX70E or equivalent .

16. See Figure 7. Tighten compensating sprocket screw (10) to 100 ft-lbs (135.6 Nm).

NOTE

Make sure shims (14) do not fall between shaft extension and alternator rotor when loosening screw.

16. Clean and prime threads of clutch hub mainshaft nut. Apply two drops of LOCTITE 262 HIGH STRENGTH THREAD- LOCKER AND SEALANT (red) to the threads. Start nut onto mainshaft. Hand-tighten.

Make sure shims (14) do not fall between shaft extension and alternator rotor when loosening screw.

17. Loosen screw one half turn (180 degrees).

18. Final tighten to 175 ft-lbs (237.3 Nm).

19. Rotate the compensating sprocket (6) to make sure that there is a light pressure on the sprocket from the springs. No clearance should be felt. A slight rotation should be possible by hand with the transmission in neutral.

20. Complete the assembly per instructions in the service manual:

- a. Assemble the remaining drive components.
- b. Adjust the clutch.
- c. Install the primary chain tensioner.
- d. Install the primary chaincase cover with a new gasket (sold separately).
- e. Fill the primary chaincase with lubricant.

RETURN TO SERVICE

21. Verify that the ignition/key switch is turned to the OFF position.

22. Apply a light coat of electrical contact lubricant, petroleum jelly or corrosion retardant material to the battery terminals. Connect the battery cables (positive cable first) as outlined in the service manual.

Warning

Connect positive (+) battery cable first. If positive (+) cable should contact ground with negative (-) cable connected, the resulting sparks can cause a battery explosion, which could result in death or serious injury. Install the seat as outlined in the service manual.

After installing seat, pull upward on seat to be sure it is locked in position. While riding, a loose seat can shift causing loss of control, which could result in death or serious injury.

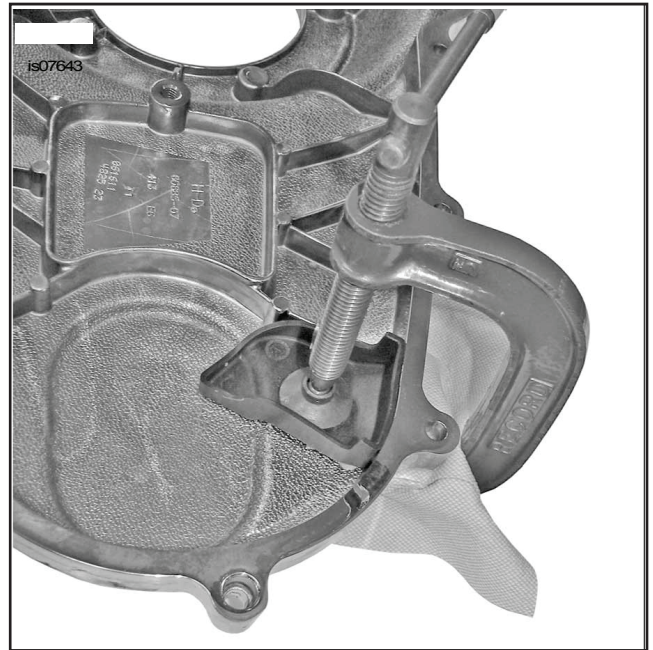

Figure 4. Clamp Components Together

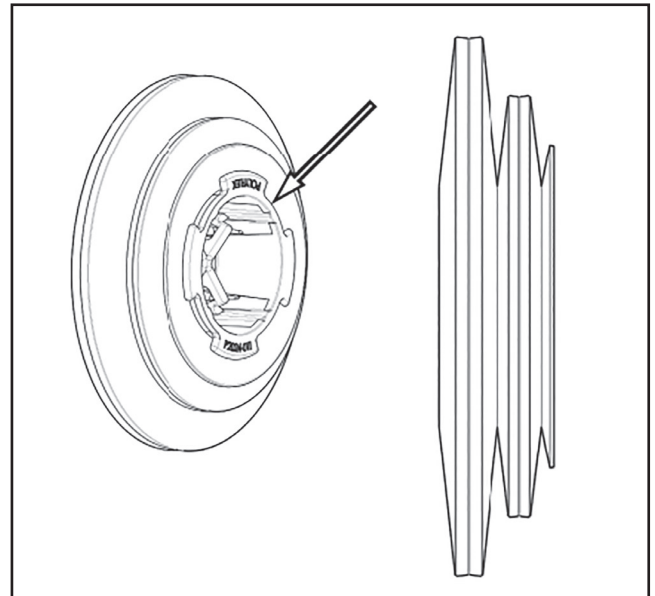
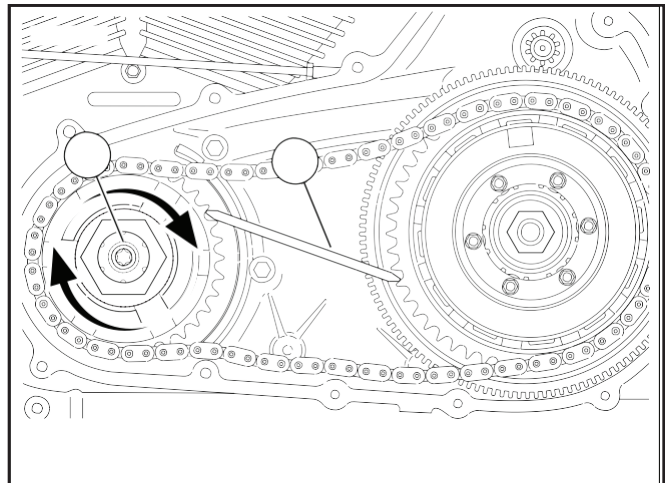

Figure 5. Spring Pack Sub-Assembly



1. Bolt
2. Primary drive locking tool

Figure 6. Installing Engine Compensating Sprocket Bolt

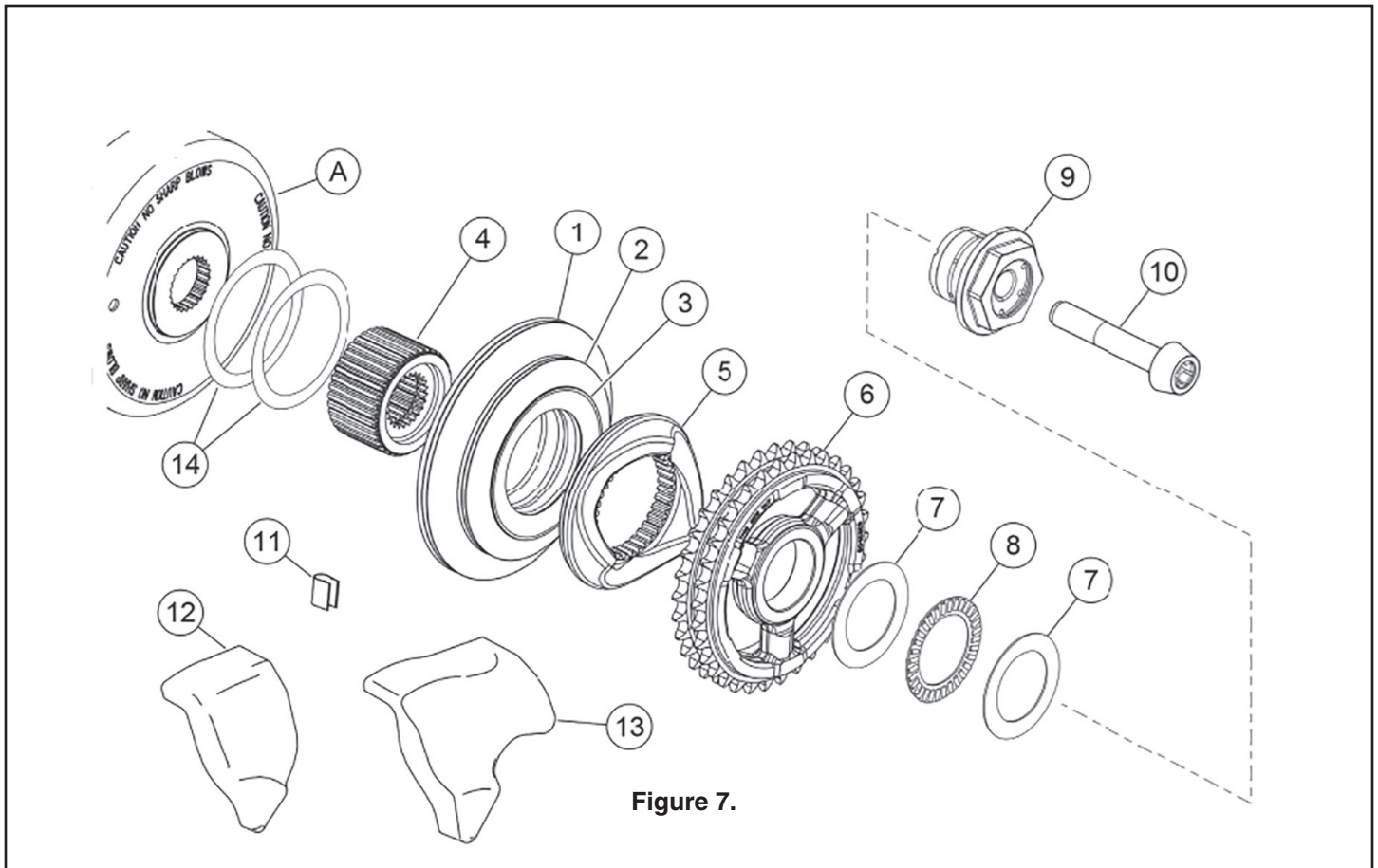

Figure 7.

Item	Description	Part Number
*	Spring Pack (includes items 1 thru 3) (INCLUDED IN KIT)	VT No. 13-0871
1	Large disc spring (2)	NOT SOLD INDIVIDUALLY
2	Medium disc spring (2)	NOT SOLD INDIVIDUALLY
3	Small disc spring (1)	NOT SOLD INDIVIDUALLY
4	Shaft extension	NOT SOLD INDIVIDUALLY
5	Sliding cam	NOT SOLD INDIVIDUALLY
6	Compensating sprocket	NOT SOLD INDIVIDUALLY
*	Bearing Service Kit (Includes Items 7 thru 8)	OEM # 36500079
7	Thrust washer (2)	NOT SOLD INDIVIDUALLY
8	Thrust bearing	NOT SOLD INDIVIDUALLY
9	Sprocket retainer	OEM# 40100041
10	Screw	OEM #10500031
11	Retainer clip	OEM# 12200065
12	Oil deflector, Touring models	OEM# 62700063
13	Oil deflector, Dyna and Softail models	OEM# 62700064
14	Shims, 0.031 (2) if required (NOT INCLUDED IN KIT)	VT No. 12-0001
A	Alternator Assembly, if required (NOT INCLUDED IN KIT)	VT No. 32-0870