

VT No. 22-0957, 22-0958

WARNING

The rider's safety depends upon the correct installation of this kit. Use the appropriate service manual procedures. If the procedure is not within your capabilities or you do not have the correct tools, have a dealer perform the installation. Improper installation of this kit could result in death or serious injury.

NOTE

This instruction sheet references service manual information. A service manual for your model motorcycle is required for this installation and is available from a dealer.

INSTALLATION

See the service manual. Remove right footrest and rear brake pedal assembly. Retain pin and clevis for installation of kit.

See the service manual. Remove left footrest and shift lever assembly. Retain shifter peg and hardware for installation of kit.

See the service manual. Install parts from this kit and shifter peg and hardware retained from removal process.

NOTE

Wear peg application:

C-models - short wear pegs (33129-06).

N-models - no wear pegs.

All other models - long wear pegs (33130-07A).

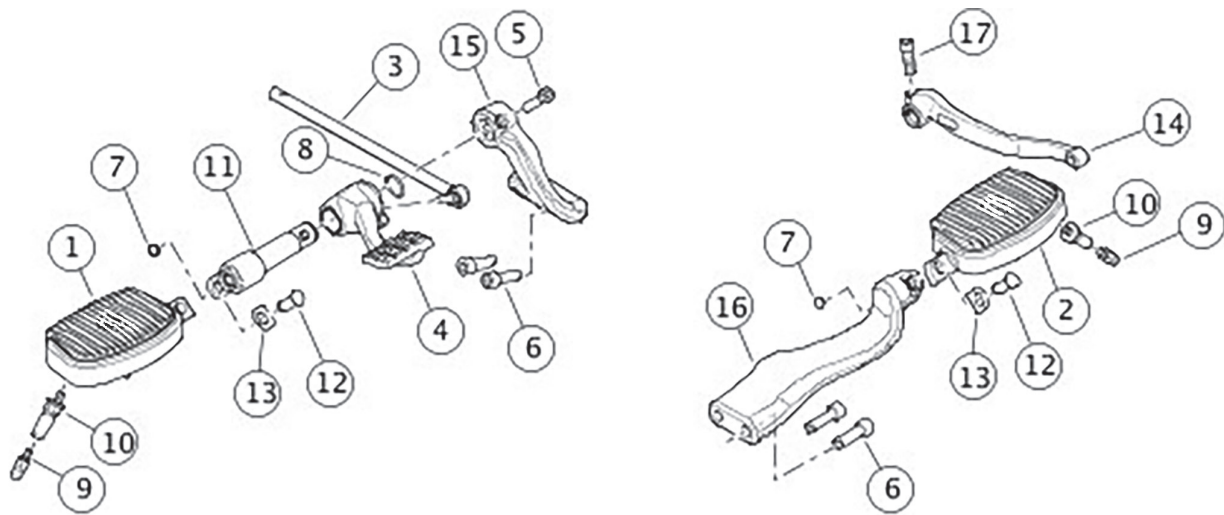

SERVICE PARTS

Figure 1. Service Parts: XL Farther Forward Control Kit

Table 1. Service Parts Table

Item	Description (Quantity)	Part Number
1	Mini footboard, right (chrome)	Not Sold Separately
	Mini footboard, right (black)	50500451
2	Mini footboard, left (chrome)	Not Sold Separately
	Mini footboard, left (black)	50500452
3	Pushrod assembly, mid control	50600125
4	Brake pedal assembly, mid control	Not Sold Separately
5	Screw	3162
6	Screw 3/8-16 x 3.175 cm (1.25 in) long (4)	3214
7	Retaining ring (2)	11304
8	Retaining ring	11390
9	Wear peg (2)	33129-06
10	Wear peg (2)	33130-07A
11	Clevis, rider footpeg (2)	42541-04
12	Clevis pin, footpeg (2)	45041-01A
13	Spring washer, pedal	50912-72
14	Shifter, pedal	33900154
15	Footpeg mount, right	Not Sold Separately
16	Footpeg mount, left	Not Sold Separately
17	Screw	2708A