

USER INSTRUCTIONS  
FOR  
**VT No. 32-9159**

**Programmable Digital  
Ignition System  
For  
Harley-Davidson Motorcycles**

DESCRIPTION

The DYNA 2000i Digital Ignition system for Harley-Davidson motorcycles is a self contained upgrade to the electronic advance ignition found on late model Harleys. This ignition is microcomputer controlled, generating extremely accurate control over the entire ignition process. The DYNA 2000i is without question the most sophisticated and capable aftermarket ignition available for Harley-Davidsons.

In addition to providing precise control over the ignition process, the DYNA 2000i allows you to tailor the advance curve and rev limiter to the specific needs of your particular engine. The ignition timing curve is completely programmable. The rev limit is programmable with 50 RPM resolution.

The DYNA 2000i replaces the stock Hall effect pickup found on the camshaft of all late model Harleys. Earlier model bikes without factory electronic ignition can also use the DYNA 2000i by installing a rotor from any late model bike. The DYNA 2000i can be used with either one Ignition coil (dual fire mode) firing both cylinders, or with two ignition coils (single fire mode), one coil firing each cylinder.

A separate tach output is included on the DYNA 2000i to allow correct tach operation during rev limiting and when in single fire mode. Two diagnostic LED indicators are included on the ignition module to assist in trouble shooting and static timing.

INSTALLATION NOTES

**\*\*IMPORTANT\*\*** On any electronic advance ignition such as the DYNA 2000i or the stock Harley ignition, you must use carbon, graphite or spiral core type suppression spark plug wires with a resistance in the range of 300 to 4000 ohms per foot to reduce radio frequency interference. Use of metal core wires may cause malfunction of the ignition due to severe electrical noise generated at the spark plugs. The original wires supplied by Harley-Davidson are acceptable. Suppression wires are also available from DYNATEK.

**\*\*IMPORTANT \*\*** - The stock pickup assembly consists of two pieces, a sensor plate and a rotating cup attached to the camshaft. The rotating cup used on 1983 and later Harleys has part number 32402-83 stamped on it and is gold in color. This is the correct cup to use with the DYNA 2000i. Pre 1983 electronic ignition bikes have a silver colored cup with different window widths. The DYNA 2000i advance curves will not work properly with the old cup design. If you have one of these older cups, get a newer cup with the above part number from your Harley dealer.

Bikes originally equipped with points (except distributors) or early electronic ignition (Prestolite) will accept the later model cup without modification.

## DUAL FIRE INSTALLATION (One coil firing both cylinders)

Recommended Coil: Use one dual output coil with a primary resistance of 2.8 to 3.5 ohms, such as DYNATEK Part No. DC6-1, or Part No. DC1-1, or stock Harley coil, or Screamin' Eagle Harley coil. For dual plug applications, 2 DC2-1 or DC5-1 coils wired in **series** can be used.

1. Locate the stock ignition module and remove it from the bike. Remove the outer and inner covers on the cam position sensor. Mark the center of the actual sensor on the inside of the engine case. Unplug the cam position sensor from the harness, and remove the cam position sensor. The pins may be removed from the connector housing by slowly but firmly pulling the wires from the rear of the connector housing.
2. Feed the wires of the DYNA 2000i through the hole in the engine case. Place the DYNA 2000i in the engine with the timing pickup (near the switches) at the mark made in step 1. Install the two screws that held the stock cam position sensor, finger tight.
3. Coil connection. Typically, there is a white wire from the Run/Stop switch on one of the coil primary terminals. On the same terminal, there is a second white wire going to the stock ignition module. These wires are the +12V supply to the coil and the +12V supply wire to the stock ignition module. On the other coil primary terminal, you should find a pink wire from the stock ignition module. This is the coil minus wire from the ignition module. There may be a second pink wire from the tach. Remove all these wires from the coil.

**Note:** On later model bikes, there is only one white wire (w/black stripe) and one pink (w/black stripe) connected to the coil. The +12 volt supply for the module, and the tach input, are spliced into the harness at some other point.

Locate the original white wire on the bike that is the +12v supply from the ignition switch to the coil (discussed above). Connect this original white wire and the white wire from the DYNA 2000i to one of the coil primary terminals. Locate the pink wire from the DYNA 2000i. Connect this wire to the unconnected primary terminal on the coil.

4. Tach signal connection (if equipped). If there was a second pink wire to the tach, the green wire from the DYNA 2000i may be connected to it with the supplied connectors.

If your bike had only one pink wire at the coil, connect the green wire from the DYNA 2000i to the stock pink wire with the supplied connector.

**Do not** reconnect the green wire to the coil or damage to the ignition may result. Verify that the stock pink wire(s) are **not** connected to the coil.

5. Remove the stock purple wire from the VOES. Connect the purple wire from the DYNA 2000i to the VOES with the .187" receptacle terminal.

The blue wire is left unconnected. If there is no tach, the green wire is left unconnected.

6. Skip to the "Programming the Ignition" section of these instructions.

## SINGLE FIRE INSTALLATION (Two coils, one firing each cylinder)

**Recommended Coil(s):** For best performance and ease of installation, the Dyna Twin Fire Performance Coil is recommended. Use Dynatek part no. DC6-5 for single plug or DC6-4 for dual plug applications. Two separate coils with a primary resistance of 2.8 to 3.5 ohms, such as part no. DC3-1 single output coils or part no. DC1-1 or DC6-1 dual output coils for dual plugged heads may also be used. Mounting brackets for two coil setups are available from the major Harley parts distributors.

1. Follow the "Dual Fire Installation Instructions" above, through step 2.
2. Remove the original single coil. Typically, there is a white wire from the Run/Stop switch on one of the coil primary terminals. On the same terminal, there is a second white wire going to the stock ignition module. These wires are the +12V supply to the coil and to the stock ignition module. On the other coil primary terminal, you should find a pink wire from the stock ignition module. This is the coil minus wire from the ignition module. There may be a second pink wire from the tach. Remove all these wires from the coil.

**Note:** On later model bikes, there is only one white wire (w/black stripe) and one pink (w/black stripe) connected to the coil. The +12 volt supply for the module, and the tach input, are spliced into the harness at some other point.

3. Mount the ignition coils firmly so they can withstand normal vehicle vibration without loosening or bracket fatigue. Assign one coil to the front cylinder and one to the rear cylinder. Spark plug wires should be connected accordingly.

4. If a DC6-5 twinfire coil is used, locate the original white wire on the bike that is the +12v supply from the ignition switch to the coil (discussed above). Connect the original white wire and the white wire from the DYNA 2000i to the terminal labeled +.

If separate coils are used, locate the 6 inch white jumper wire included in the DYNA 2000i kit. Connect this jumper wire from one of the primary terminals (terminal marked "+" on DC3-1 coil) on the front cylinder coil to one of the primary terminals on the rear cylinder coil. Locate the original white wire on the bike that is the +12v supply from the ignition switch to the coil (discussed above). Connect this original white wire and the white wire from the DYNA 2000i to one of the coil primary terminals with the white jumper wire attached.

5. Locate the pink wire from the DYNA 2000i. Connect this wire to the unconnected primary terminal on the rear cylinder coil. Locate the blue wire from the DYNA 2000i. Connect the blue wire to the unconnected primary terminal on the front cylinder coil.

6. Tach signal connection (if equipped). If there was a second pink wire to the tach, the green wire from the DYNA 2000i may be connected to it with the supplied connectors.

If your bike had only one pink wire at the coil, connect the green wire from the DYNA 2000i to the stock pink wire with the supplied connector.

**Do not** reconnect the tach wire to the coil or damage to the ignition may result. Verify that the stock pink wire(s) are **not** connected to the coil.

7. Remove the stock purple wire from the VOES. Connect the purple wire from the DYNA 2000i to the VOES with the .187" receptacle terminal.

If there is no tach, the green wire is left unconnected. The green tach wire is used for programming. DO NOT cut it off.

Your system is now completely wired. After programming the ignition and checking the timing, you will be ready to run.

## PROGRAMMING the IGNITION

Connect the programming adapter to the serial cable and the bike before turning the bike's ignition on. **DO NOT** start the bike. The green LED will remain lighted while the programming adapter is connected. Follow the separate instructions included with the CurveMaker software.

### Programming Adapter Wire Connections

<u>Adapter</u>	<u>Bike</u>
White	12 volts
Black	Ground (engine case)
Green	Ignition tach wire (green)
Purple	Ignition VOES wire (purple)

## DEVELOPING AN ADVANCE CURVE

The most appropriate advance curve for your engine will depend on several factors. These may include: level of modification of the engine, weight of bike and rider, type of gasoline used, air temperature, altitude, etc.

For tuners who are familiar with previous Dyna 2000 ignitions, the four curves used in the standard (non-programmable) 2000i are included in the CurveMaker software. A good procedure would be to start with Curve 2, which is similar to the curve in the stock ignition module. If you experience any "pinging", try Curve 3 then curve 4 if necessary to get rid of the pinging. If your bike runs well on Curve 2, try Curve 1 after several miles and find out if your motor likes Curve 1 better than Curve 2. Generally, you should run the lowest number curve (most aggressive) that you can without causing any pinging. Any of the included curves may be used as a base for developing a completely custom curve. The actual curves are shown at the end of these instructions.

## SETTING OTHER PARAMETERS

The Timing page of the CurveMaker software has entries for the rev limit and number of dead revolutions while cranking. The valve train of most stock motors can be safely revved to 6000 RPM. Motors with wild cams and stock valve springs (generally a bad idea) may require lower rev limits. Motors with a well-matched valve train (using valve springs recommended by the cam manufacturer) may be revved higher.

---

~~Electric start motors generally reach full cranking speed in two or three revolutions. The ignition is shipped from Dynatek with Dead Revs set to three. This is more than adequate to prevent starter kickback on most motors.~~

**KICKSTART NOTE:** To kickstart a motor, it will be necessary to set Dead Revs to zero. The motor must be kicked through a complete compression stroke, without stopping, to make a spark. Follow this procedure: With the timing cover removed so the red LED can be seen (have an assistant view the LED), position the crankshaft as you normally would to kickstart the motor. If, before kicking the motor over, the red LED is on, the crankshaft is stopped on the compression stroke. Slowly move the kicklever until the red LED goes off, indicating the motor is past Top Dead Center. Return the kick lever to the beginning of it's stroke, and kick the motor over. The ignition will make a spark at TDC after one engine revolution. Practice this procedure a few times before installing the timing cover, to get a feel for Top Dead Center.

## DIAGNOSTIC LED FUNCTION

A red diagnostic LED is located on the DYNA 2000i ignition module. This LED is useful for verifying system functionality and static timing the motor.

### VERIFYING SYSTEM FUNCTIONALITY WITH THE LED

The red LED can be used to determine if the ignition module is working. When power is turned on to the ignition, the LED should flash on for 1/4 second then turn off. If the pickup is near a firing point, the red LED will come on continuously. This "Flash period" indicates that the microprocessor is functioning in the DYNA 2000i ignition module.

When the ignition power is on and the engine is cranked over, the red LED on the DYNA 2000i will blink on and off. This indicates that the DYNA 2000i pickup is generating timing. The pickup is designed such that the LED will come on at about 45 degrees before top dead center and go off at top dead center for each cylinder. This corresponds to the leading edge of the window in the rotating cup (45 BTDC), and the trailing edge (TDC).

NOTE: If the red LED flashes rapidly with the engine not running, an overcurrent fault is indicated. Check for proper coil resistance (2.5 to 3.5 ohms) and wiring. Turn the ignition off for one second, and back on to clear the fault.

### VOES LED FUNCTION

The green VOES LED lights when the purple wire is grounded. When the engine is operated in normal mode with the VOES connected, the green LED will be on most of the time. The green LED will also be on when the Programming Adapter is connected.

### V.O.E.S. Switch

All late model Harley-Davidson Evolution engines incorporate a Vacuum Operated Electric Switch (VOES) in the intake manifold. This switch is connected to the ignition system through the purple wire. The purpose of this switch is to sense high manifold vacuum conditions during part throttle operation. When the manifold vacuum is high, the VOES switch grounds the purple wire and jams the stock ignition module to full advance regardless of what the engine RPM is. As it turns out, the VOES switch is almost always closed, causing the stock ignition to be at full advance nearly all the time except under wide open throttle conditions.

The DYNA 2000i module uses the VOES in a slightly different manner. When the VOES is active (grounded), the DYNA 2000i module follows the Part Throttle advance curve. The Wide Open Throttle and Part Throttle advance curves are completely and separately programmable. Using this advance scheme, the DYNA 2000i always provides ~~a smooth continuous advance curve function that is optimized for both part and full throttle operation.~~ The traditional Dyna 2000 advance curves are shown at the end of these instructions.

### STATIC TIMING THE MOTOR WITH THE LED

Static timing is easy with the DYNA 2000i. Remove the timing inspection plug above the primary drive housing on the left side of the motor. Remove the spark plugs to make it easy to turn the crankshaft. With the bike in high gear move the rear wheel to get the crankshaft to top dead center on the compression stroke of the front cylinder (TDC mark aligned in the inspection hole).

### TIMING SET

Rotate the DYNA 2000i to cause the red LED to turn off and on. Carefully follow this next instruction: find the point where the LED just turns off while rotating the base plate in a clockwise direction. Lock down the 2000i at this location. Verify that the crankshaft is still on top dead center. Your base timing should now be set perfectly.

If the DYNA 2000i has to be rotated an extreme amount or does not have enough adjustment to bring the timing in, the engine may be on its exhaust stroke. Remove the 2000i and observe the timing rotor. The timing pickup (near the switches) should be sitting in one of the windows when it is in place. The shorter distance to the other window should be CLOCKWISE. If it is not, rotate the crankshaft 360 degrees and check again.

## TIMING CHECK

For a double check on the timing, while still in gear rotate the rear tire so the engine is before top dead center on the front cylinder compression stroke, then slowly rotate the crankshaft forward to top dead center and observe the LED turn off as the TDC mark on the flywheel passes the inspection window.

Replace the spark plugs and timing inspection plug and start the engine.

## DYNAMIC TIMING

The DYNA 2000i timing can be checked dynamically (with the engine running). This is normally not necessary, but if you want to check the timing in this manner, use the following procedure:

- Program the ignition with Traditional curve #1. This will cause the ignition to go to 35 degrees advance at 1500 RPM and above.
- If you are not using the VOES switch, ground the purple wire to the frame or engine. This will cause the quick Part Throttle curve to be active.
- Now use a timing light connected to the front cylinder plug wire to observe the flywheel timing marks through the inspection hole on the left side of the engine.
- When the engine rpm is above 1500 rpm, the full advance mark should come into view in the inspection hole.
- This will verify that the DYNA 2000i is set properly. Now reprogram the curve you want to run

Note: The timing mark on 1995 and later Evo flywheels is for idle advance. A "dialback" timing light must be used, with the TDC mark on the flywheel.

## TUNING TIPS - ADVANCED

Occasionally, best performance may fall somewhere between the advance curves programmed into the DYNA 2000i. By rotating the 2000i clockwise (advanced) or counter-clockwise (retarded), the entire curve will be shifted up or down. Be aware that if you advance the ignition, your final timing will be increased. Excessive advance may cause pinging and hard starting, so only turn the 2000i one or two degrees at a time and note any changes to the motor.

For racing applications, the advance can be set to always come in quickly by using NORMAL VOES mode and permanently connecting the VOES wire to ground. These curves are similar to what is generated by a mechanical advancer.

---

For heavy bikes or bull motors that tend to detonate, the advance can be brought in more slowly. If the VOES wire is left unconnected, the advance will always follow the slower rpm curve as shown on the following graph.

**DUAL-FIRE/SINGLE-COIL  
WIRING DIAGRAM**

COIL:  
FACTORY H-D OR DYMATEK  
PART NUMBER DC6-1.

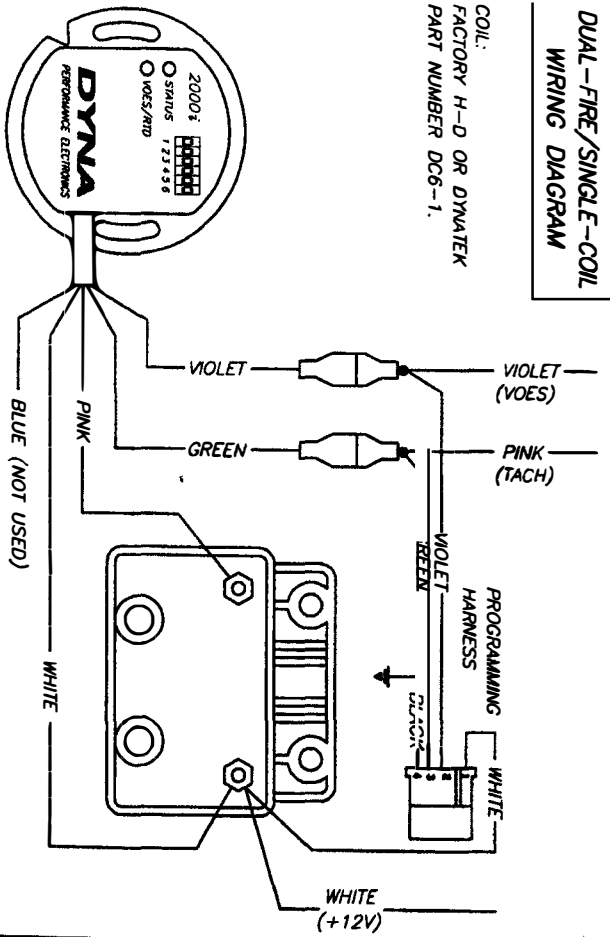

**DUAL-FIRE/DUAL-COIL  
WIRING DIAGRAM**

COILS:  
DYMATEK PART NUMBER DC3-1  
OR DC5-1.  
(DC2-1 COILS SHOWN)

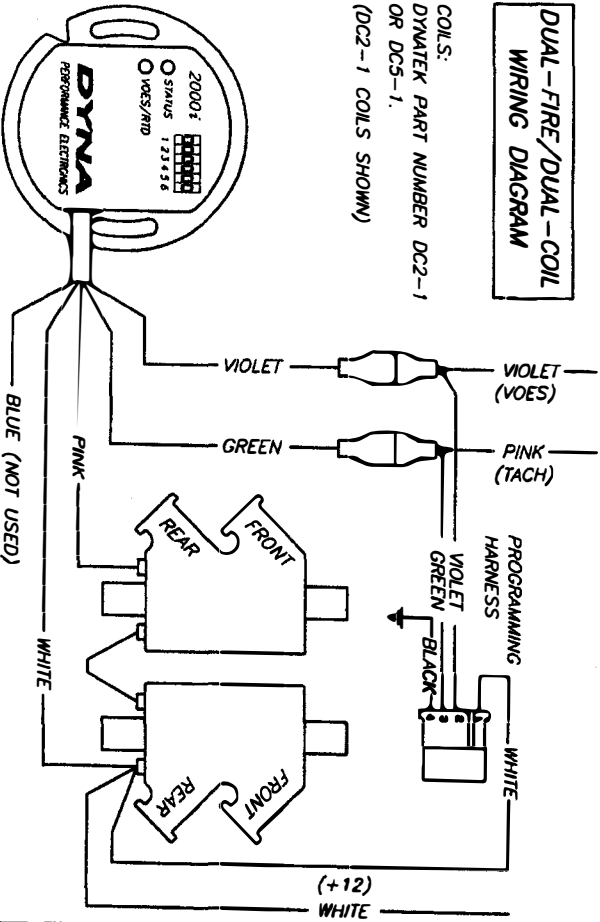

**SINGLE-FIRE/DUAL-COIL  
WIRING DIAGRAM**

COILS:  
DUAL PLUG: DYMATEK DC1-1  
SINGLE PLUG: DYMATEK DC3-1

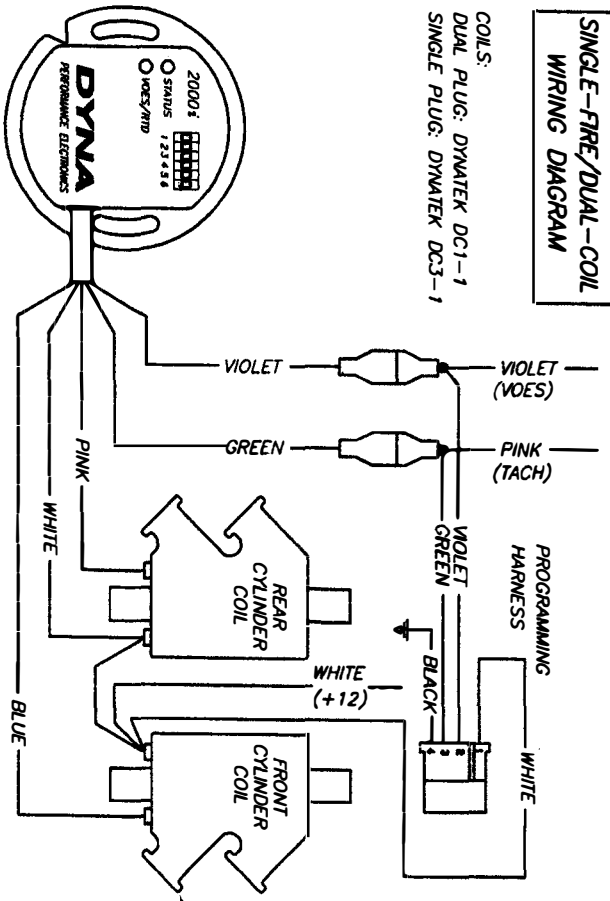

**SINGLE-FIRE/SINGLE-COIL  
WIRING DIAGRAM**

COIL:  
DYMATEK DC6-5 TWIN-FIRE II

NOTE:  
OUTPUTS CAN BE REVERSED  
FOR BEST SPARK PLUG WIRE  
ROUTING BY SWAPPING PINK  
AND BLUE PRIMARY  
CONNECTIONS.

