

# FENDER EDGE LIGHT KIT

## GENERAL

### Kit Numbers

73416-11, 73420-11

### Models

### ⚠ WARNING

The rider's safety depends upon the correct installation of this kit. If the procedure is not within your capabilities or you do not have the correct tools, have a dealer perform the installation. Improper installation of this kit could result in death or serious injury.

### Additional Parts Required

### Electrical Overload

### NOTICE

It is possible to overload your vehicle's charging system by adding too many electrical accessories. If the combined electrical accessories operating at any one time consume more electrical current than the vehicle's charging system can produce, the electrical consumption can discharge the battery and cause damage to the vehicle's electrical system. See a dealer for advice about the amount of current consumed by additional electrical accessories or for necessary wiring changes.

### ⚠ WARNING

When installing any electrical accessory, be certain not to exceed the maximum amperage rating of the fuse or circuit breaker protecting the affected circuit being modified. Exceeding the maximum amperage can lead to electrical failures, which could result in death or serious injury.

This Fender Edge Light Kit requires up to **42 mA** additional current from the electrical system.

### Kit Contents

See Figure 4 and Table 1.

## INSTALLATION

### ⚠ WARNING

To prevent accidental vehicle start-up, which could cause death or serious injury, remove main fuse before proceeding.

1. See the owner's manual and remove the seat and main fuse.
2. Remove the stock reflector from the rear of the fender if installed.

### NOTE

The surface of the rear fender where the fender edge light will be mounted **must be very clean** for the adhesive pads of the light to properly adhere.

3. Thoroughly clean the area inside the rear fender where the fender edge light will be mounted and along the inner left side of the fender where the wire clips may be mounted:
  - a. Clean the mounting area of the fender thoroughly with soap and water.
  - b. Clean the mounting area of the fender with an approximately 1:1 mixture of isopropyl alcohol and water.
  - c. Allow the fender to dry completely.
4. See Figure 1. Test the fit of the fender edge light into the open end of the rear fender to verify that the fender edge light will fit properly without obstruction.

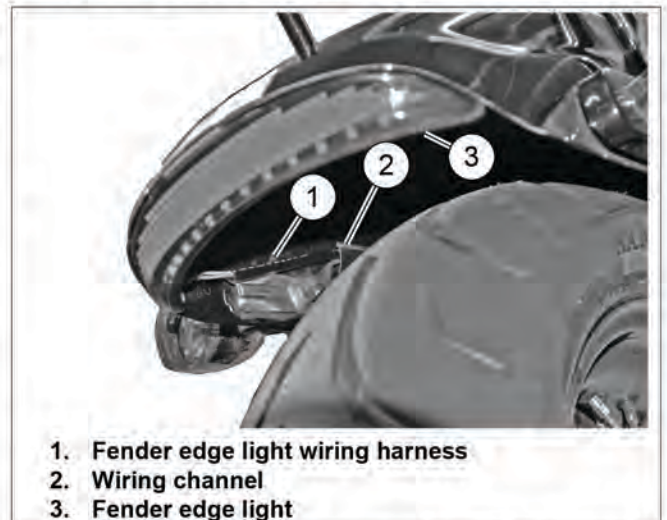

Figure 1. Fender Edge Light - Dyna Shown, Sportster Similar

- See Figure 4. Remove the protective tape (A) from the three adhesive pads on the fender edge light (1).

**NOTE**

The adhesive pads of the fender edge light are pressure sensitive. Press each adhesive pad firmly in place by hand for best adhesion.

- Press the fender edge light firmly into place in the open end of the rear fender.
- Remove the protective tape from the adhesive pad (B) of the reflector mount (7) and install the reflector to the center of the fender edge light. Press firmly in place for best adhesion.

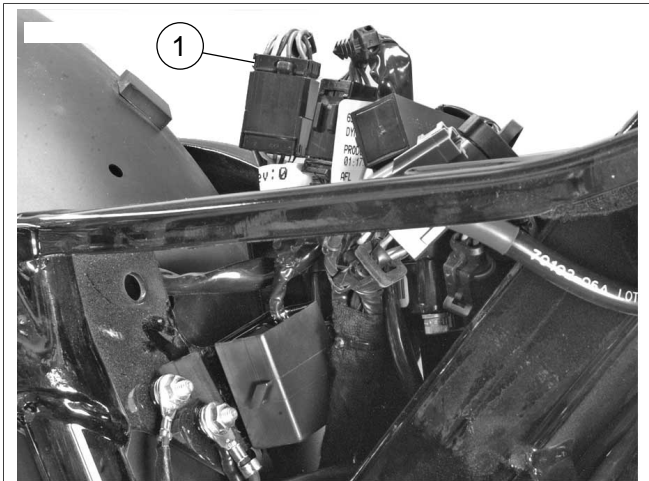

1. Rear lighting harness connector [7B]

Figure 2. Rear Lighting Harness Connector - Dyna Models

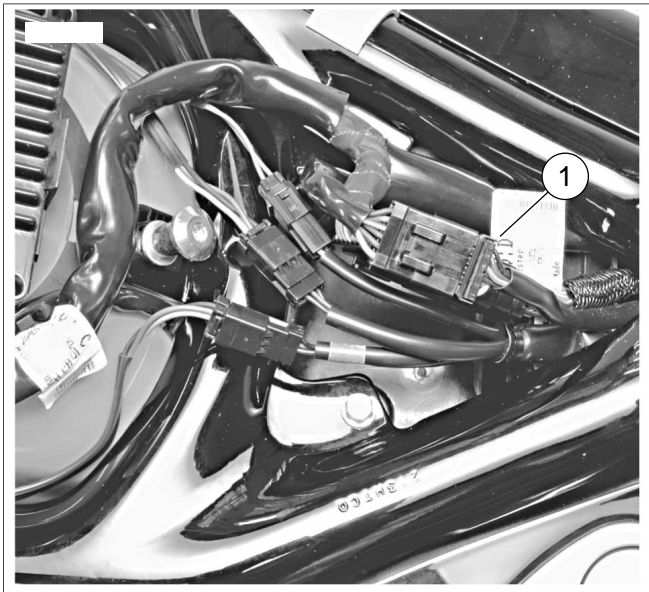

Figure 3. Rear Lighting Harness Connector - Sportster Models

## WIRING

- See Figure 2 or Figure 3. Locate and disconnect rear lighting harness connector [7B] from the main wiring harness connector [7A].

- For Dyna models:** See Figure 4. Connect interconnect harness (3) to rear lighting harness connector [7B] and main wiring harness [7A].

**For Sportster models:** See Figure 4. Connect interconnect harness (4) to rear lighting harness connector [7B] and main wiring harness [7A].

**NOTE**

The surface of the rear fender where the wire clips will be mounted **must be very clean** for the adhesive pads to properly adhere.

- For Dyna models:** See Figure 1. Route the light assembly wiring harness along the inner left side of the fender through the wiring channel (2) to the front of the fender. Then route the harness to pass through of the fender to the seat pan area and the interconnect harness. Use wire clips as necessary to secure the wire harness.

**For Sportster models:** Route the light assembly wiring harness along the inner left side of the fender to the fender pass through hole. Secure the wire harness to the inner fender wall with wire clips from the kit. Then route the harness to pass through of the rear fender to the seat pan area and the interconnect harness.

**NOTE**

See the service manual for additional information on assembling the Multilock connector, if necessary.

- See Figure 4. Insert the wires and terminals from the light assembly harness into the pin housing (2) from the kit:
  - Insert the **blue** wire into cavity 1.
  - Insert the **red/yellow** wire into cavity 2.
  - Insert the **black** wire into cavity 3.

- Connect the light assembly harness to the interconnect harness 3-place connector.
- Secure the interconnect harness in the seat pan area as necessary with cable straps (6).

## RETURN TO SERVICE

- Refer to the owner's manual and follow instructions to install the main fuse.
- Turn the ignition key switch to IGNITION, but do not start the motorcycle.

Test the fender edge light **and** the motorcycle lamps for proper operation:

- With the ignition switch on, the LEDs in the fender edge light should be illuminated, along with the vehicle tail lamps.
- When either the brake hand lever of foot pedal are activated, the LEDs in the fender edge light should noticeably brighten, along with the vehicle stop lamps.
- When either turn signal switch is activated, the LEDs in the fender edge light should remain lit steadily, and not flash.
- Turn the ignition key switch to OFF. The fender edge light should turn off immediately, along with the vehicle tail lamps.

**WARNING**

After installing seat, pull upward on seat to be sure it is locked in position. While riding, a loose seat can shift causing loss of control, which could result in death or serious injury.

3. Refer to the owner's manual and follow instructions to install the seat.

**SERVICE PARTS**

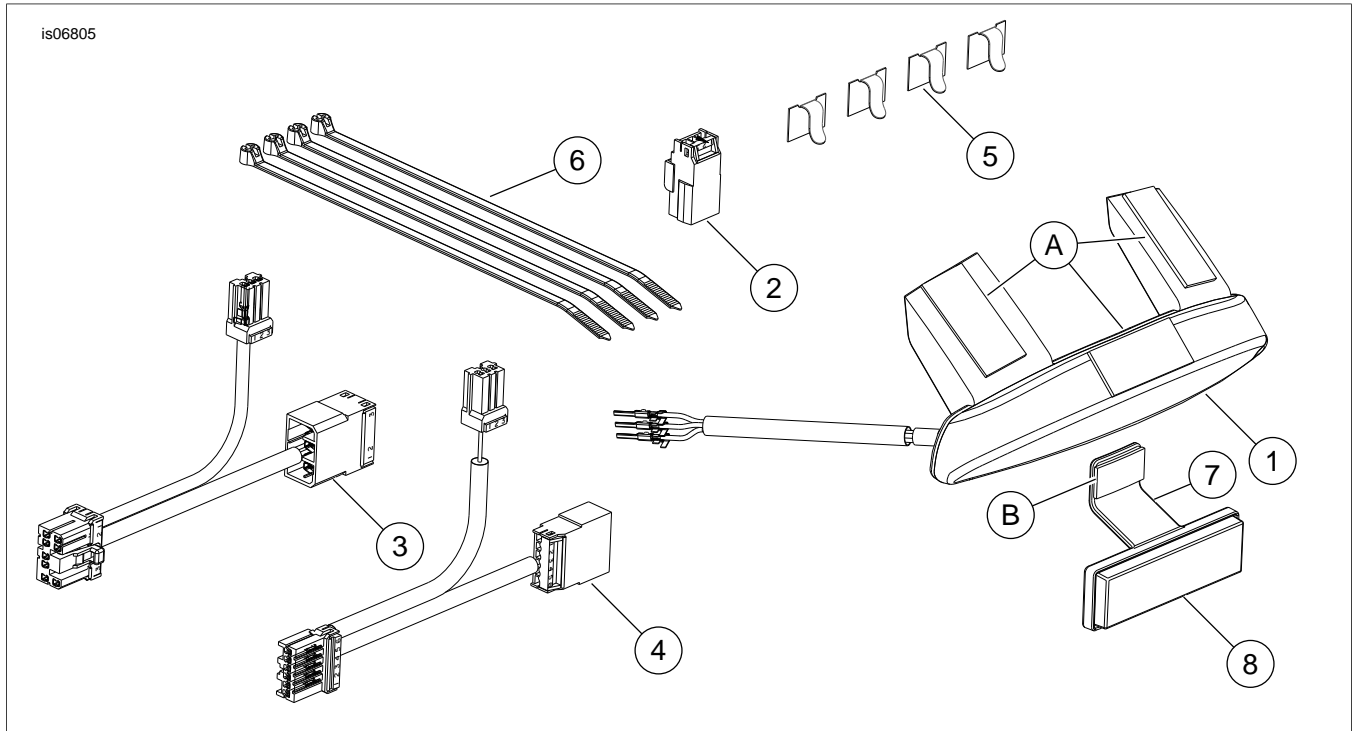

Figure 4. Service Parts: Fender Edge Light Kit

Table 1. Service Parts

| Item                            | Description (Quantity)   | Part Number         |
|---------------------------------|--|---------------------|
| 1                               | Fender edge light assembly   | Not sold separately |
| 2                               | Pin housing, three-way   | 73103-96BK          |
| 3                               | Harness, interconnect, Dyna models (included in kit 73416-11)      | Not sold separately |
| 4                               | Harness, interconnect, Sportster models (included in kit 73420-11) | Not sold separately |
| 5                               | Clip, adhesive-backed (4)  | 10102               |
| 6                               | Cable strap (4)  | 10006               |
| 7                               | Mount, reflector   | 69599-11            |
| 8                               | Reflector  | 73315-10            |
| <b>Items mentioned in text:</b> |  |                     |
| A                               | Adhesive pads  |                     |
| B                               | Adhesive pad   |                     |