

**SADDLEBAG FILLER STRIP KITS**  
**VT No. 50-1135 and 50-1136**

See Page 2

**Figure Number Description**

1	1993 FLHS or 1993-1994 Dresser without Saddlebag Guard Rail 1994 FLHR (use slotted filler strips with Nostalgic Guard Rail)
2	1993 FLHS or 1993-1994 Dresser with Saddlebag Guard Rail
3	1994 FLHR w/Detachable Rear Docking Kit (use slotted filler strips w/Nostalgic Guard Rail)
4	1995 FLHR without Nostalgic Guard Rail and with Detachable Rear Docking Kit 1995 FLHR with Nostalgic Guard Rail and with Detachable Rear Docking Kit
5	1995-later Dresser without Saddlebag Guard Rail 1995-later FLHR without Nostalgic Guard Rail 1995-later FLHR with Nostalgic Guard Rail
6	1995-later Dresser with Saddlebag Guard Rail
7	1998-later FLHRC without Nostalgic Guard Rail 1998-later FLHRC with Nostalgic Guard Rail

**NOTE**

Figures 1 through 7 show the filler strip hardware configuration for the different model motorcycles. Refer to the figure that applies to your particular model. These kits do not fit 1998 and later FLTR models.

**INSTALLATION**

**NOTE**

Figures 1, 4, 5, and 7: Filler strip can be attached in either upper or middle location, depending on accessories installed.

Figures 2 and 6: Replace guard rail with screws from kit.

1. Remove the saddlebags following the instructions in the Service Manual.
2. Place small spacers (1) directly under the screw heads.
3. Place large spacers (2) when used between fender bracket and filler strips.
4. Position the filler strips (3) and (4) so the top just clears the saddlebag mounting bracket.
5. Secure the filler strips in place with the Torx® screws (5) and (6).

**NOTE**

If installing slotted filler strip kits 45896-98 or 45897-98 (slotted filler strips are required when using Nostalgic Guard Rail) be sure to position the thin side of the slot outboard. This is the way to distinguish between right and left side filler strips.

<b>Item</b>	<b>Description (Quantity)</b>	
1	Spacer, 0.32 ID x 0.81 OD x 0.125 in. thick (4)	6116
2	Spacer, 0.33 ID x 0.88 OD x 0.18 in. thick (4)	Sold Separately
3	Filler strip, right side	Sold Separately
4	Filler strip, left side	Sold Separately
5	Torx screw, fine thread (4)	Not Sold Separately
6	Torx screw, coarse thread (4)	3655A

**Note:** Hardware items (1), (2), (5), and (6) apply to all saddlebag filler strip kits.

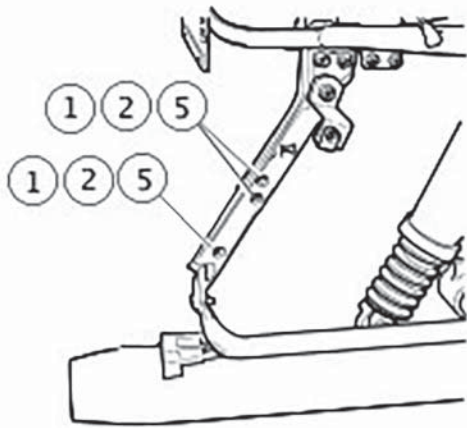

Figure 1. Filler Strip Hardware

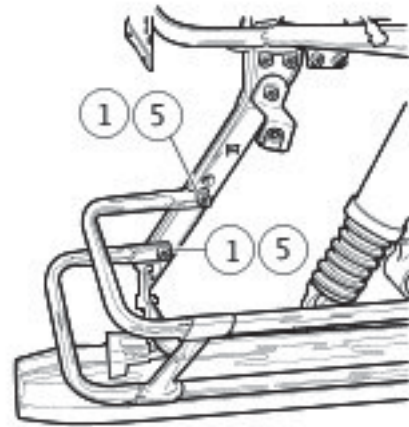

Figure 2. Filler Strip Hardware

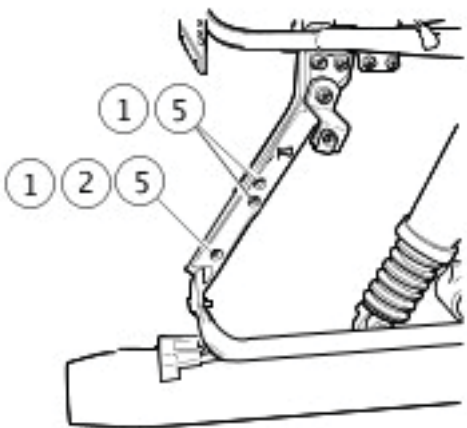

Figure 3. Filler Strip Hardware

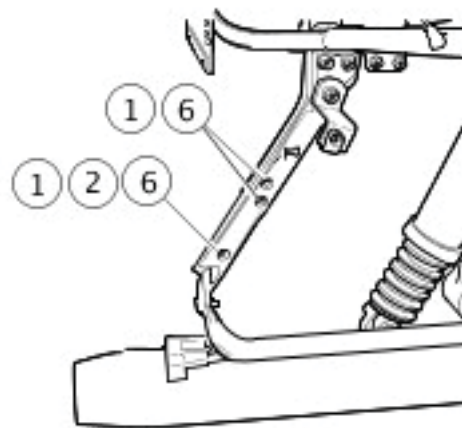

Figure 4. Filler Strip Hardware

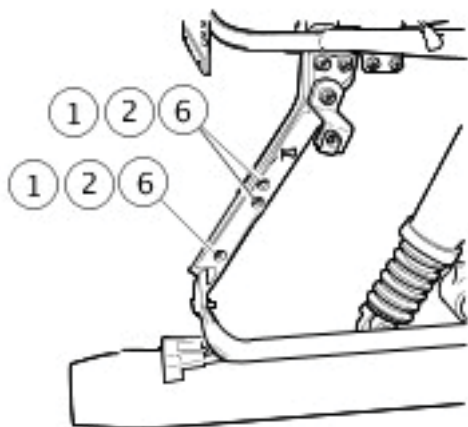

Figure 5. Filler Strip Hardware

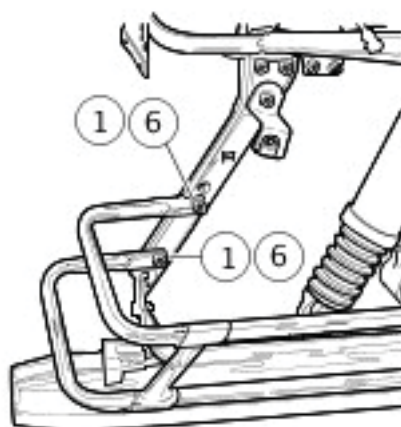

Figure 6. Filler Strip Hardware

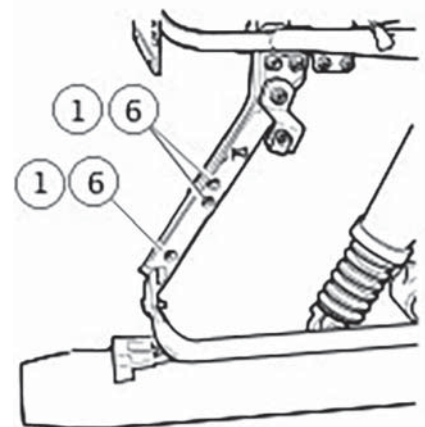

Figure 7. Filler Strip Hardware