

VT No. 50-1197 and 50-1202
Saddlebag Filler Strip Kits

WARNING

The rider's safety depends upon the correct installation of this kit. If the procedure is not within your capabilities or you do not have the correct tools, have a dealer perform the installation. Improper installation of this kit could result in death or serious injury.

INSTALLATION

Solid Filler Strips

1. Remove the saddlebags following the instructions in the service manual and set aside.
2. See Figure 1. Remove bottom saddlebag support mounting screw (4) and nut (5). Save hardware for installation.
3. Position the filler strip inside the window of the saddlebag support bracket. Align the mounting holes.
4. Secure the filler strip with screws (2) and washers (3). Tighten screws finger tight.
5. Install the filler strip to the support bracket with support mounting screw (4) and nut (5). Install screw from front to rear. Do not tighten.
6. Adjust filler strip orientation as desired. Tighten mounting hardware.
 - a. Tighten button head screws (2) to 6.8–10.8 N·m(5–8 ft-lbs).
 - b. Pan head screws (4) to 20.3–27.1 N·m(15–20 ft-lbs).
7. Install saddlebags per instructions found in the service manual.
8. Repeat procedure for opposite side.

INSTALLATION

Slotted Filler Strips

1. Remove the saddlebags following the instructions in the service manual and set aside.

NOTE

This installation requires the mounting screw and nut included in the Saddlebag Guard Rail Kit

2. See Figure 2. Remove bottom saddlebag support mounting screw (5) and nut (6). Discard hardware.
3. Remove the front interconnect (7) and middle interconnect (8) from the rails. Keep the rails roughly parallel to one another.
4. See the Saddlebag Guard Rail kit instruction sheet. Feed the rail assembly through the saddlebag support from the front to the rear. Rotate the saddlebag rail around until fit the front end of the rail aligns with the saddlebag rail.
5. Install filler strip onto guard rail, unfinished side first.
6. Position the filler strip inside the window of the saddlebag support bracket. Align the mounting holes.
7. Secure the filler strip with screws (2) and washers (3). Tighten screws finger tight.
8. See the saddlebag rail kit instruction sheet. Follow all remaining Saddlebag Guard Rail Kit installation instructions, including using the kit hardware that replaces fastener (5) and nut (6). Do not tighten filler strip mounting hardware.
9. Install front and middle guard rail interconnects.
 - a. Tighten front interconnect set screw to 4.5 N·m(40 in-lbs).
 - b. Tighten middle interconnect set screw to 7.3 N·m(65 in-lbs).
10. Adjust filler strip orientation as desired. Tighten mounting hardware.
 - a. Tighten button head screws (3) to 6.8–10.8 N·m(5–8 ft-lbs).
 - b. Pan head screws (5) to 20.3–27.1 N·m(15–20 ft-lbs).
11. Install saddlebags per instructions found in the owner's manual.
12. Repeat procedure for opposite side.

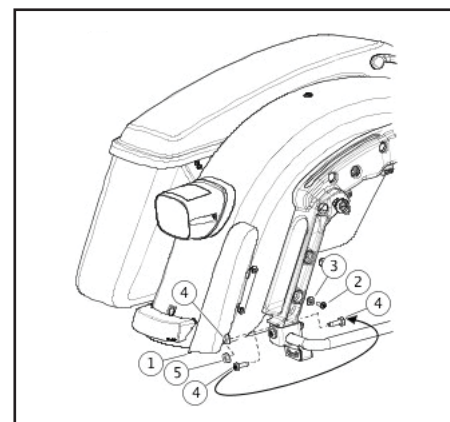

- 1 Solid filler strip
- 2 Screw (2)
- 3 Washer (2)
- 4 Saddlebag support mounting screw
- 5 Nut

Figure 1. Solid Filler Strip Installation

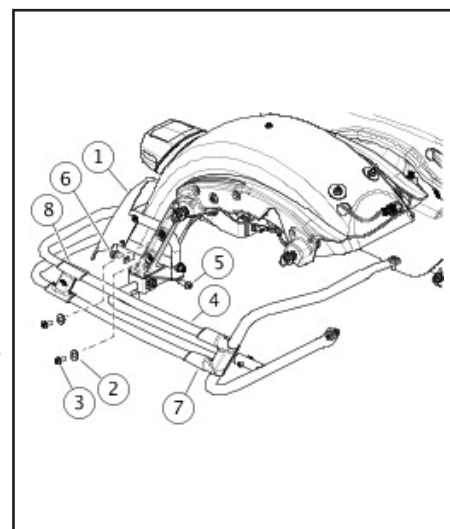

- 1 Filler strip
- 2 Screw (2)
- 3 Washer (2)
- 4 Saddlebag guard rail
- 5 Saddlebag support mounting screw
- 6 Nut
- 7 Front saddlebag interconnect w/ set screws
- 8 Middle saddlebag interconnect w/set screws

Figure 2. Slotted Filler Strip Installation