

MUSTACHE ENGINE GUARD for SPORTSTER

Kit Number

49000005 (chrome), 49000006 (black)

WARNING

Front and/or rear guard(s) can provide limited leg and cosmetic vehicle protection under unique circumstances. (Fall over while stopped, very slow speed slide.) It is not made or intended to provide protection from bodily injury in a collision with another vehicle or any other object.

NOTE

A service manual for your model motorcycle is available from a dealer.

INSTALLATION

NOTE

Cover front fender with a clean rag to protect it from scratches during installation procedures.

When performing the following steps you may also be removing the horn mounting bracket.

1. Models with horn mounted between down tubes: Note location of horn wires and remove the two horn connectors from the back of the horn.

2. See Figure 1. Remove the two screws with washers (2) securing the upper tie-link assembly (1) and horn bracket if present to the upper front frame crossmember (3). Leave tie-link assembly in position. Discard screws and washers.

3. See Figure 5. Obtain two 3/8-16 X 1-1/2 inch screws (1), two flat washers (3) and engine guard from kit (4).

NOTE

For Step 4, note that upper section of engine guard must be mounted between horn bracket and upper tie-link bracket. See Figure 3 noting that illustration does not show the horn mounting bracket.

4. Figure 3 illustrates mounting without horn bracket and horn in place. Place flat washers on screws. Obtain horn bracket with horn if present. While holding engine guard and horn bracket in place at upper crossmember, install screws with washers (2) through horn bracket, upper engine guard mount (1), tie-link mounting bracket and thread into holes in upper frame crossmember. Tighten just enough to hold the assembly snug and in place.

5. See Figure 5. Obtain two 3/8-16 X 3/4 inch screws (2) and two flat washers from kit (3).

6. See Figure 4. Install flat washers onto screws. Install screws (2) through lower engine guard mount (1) holes and thread into lower crossmember holes. Tighten until snug only.

7. By sight, carefully center the engine guard and hold in position.

8. Tighten the upper mounting screws to 34–47 N·m (25–35 ft-lbs).

9. Tighten the lower mounting screws to 34–47 N·m (25–35 ft-lbs).

10. Turn handlebars fully to the right and left and inspect for adequate clearance between the engine guard and the clutch and brake cables.

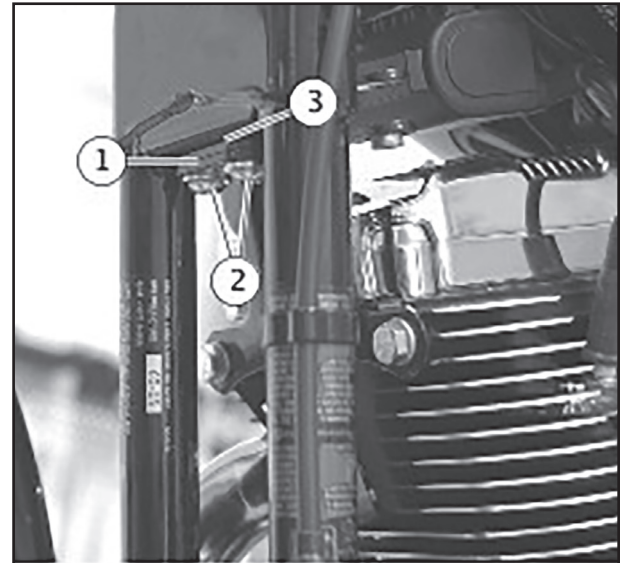

- 1 Tie-Link mounting bracket (shown without horn mounting bracket)
- 2 Screws with washers
- 3 Threaded crossmember (upper)

Figure 1. Remove upper Tie-Link to Frame Hardware (XL 1200 Custom Shown)

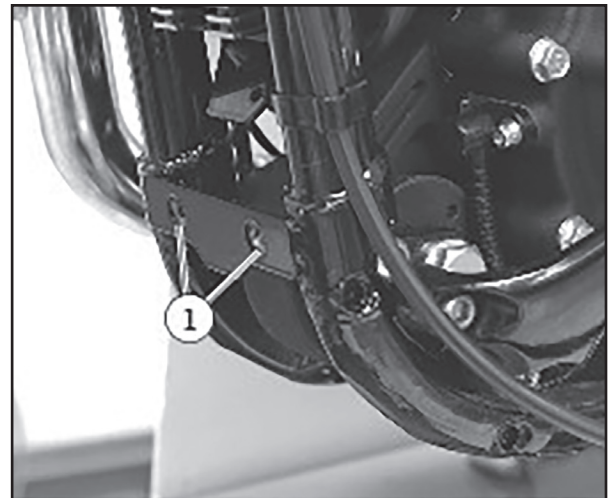

- 1 Threaded crossmember

Figure 2. Lower Frame (threaded) Crossmember

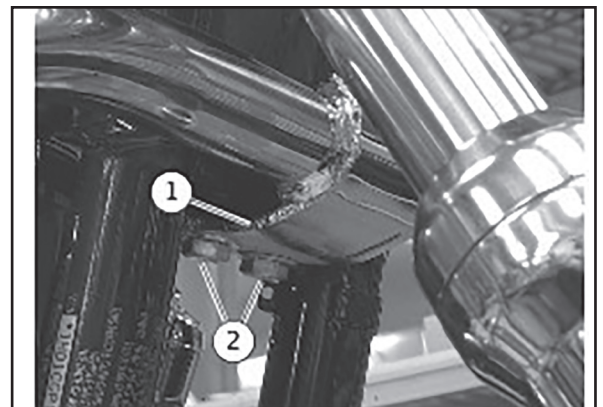

- 1 Upper engine guard mount
- 2 Screws and washers

Figure 3. Mount Upper Section of Engine Guard

Table 1. Service Parts Table

SERVICE PARTS

| Item | Description (Quantity) | Part Number |
|------|----------------------------------|---------------------|
| 1 | Screw, 3/8-16 x 1-1/2 inch (2) | 4721 |
| 2 | Screw, 3/8-16 x 3/4 inch (2) | 4713W |
| 3 | Washer, flat 3/8 inch (4) | 6026 |
| 4 | Assembly, engine guard (chrome) | Not Sold Separately |
| | Assembly, engine guard (black) | Not Sold Separately |
| 5 | Foot pad service kit (not shown) | 49000034 |

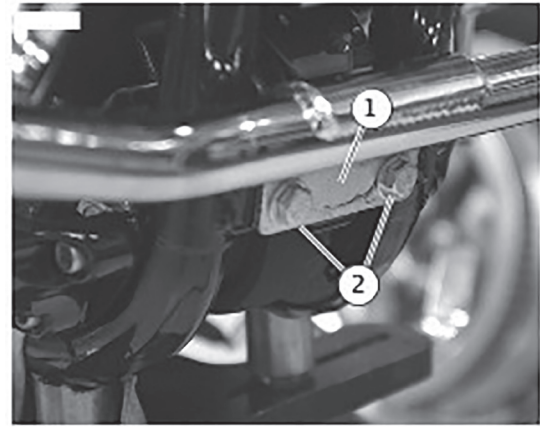

- 1 Lower engine guard mount
- 2 Screws and washers

Figure 4. Mount Lower Section of Engine Guard

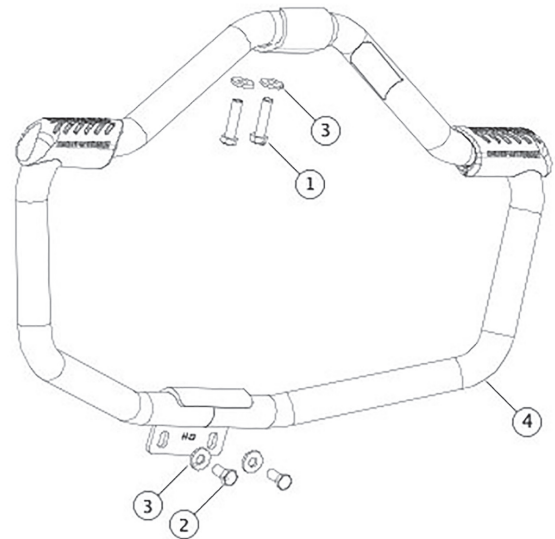

Figure 5. Sportster Mustache Engine Guard