

V-Twin Mfg.
NATIONAL BEADED WINDSHIELD, BLACK
FITS 1960-1984 FLH
VT No. 51-0303

This is a custom application and rider safety depends on proper installation. This product should only be installed by a knowledgeable and trained motorcycle technician. V-Twin Mfg. accepts no responsibility for improper installation.

Installation of Spacers and Clamps

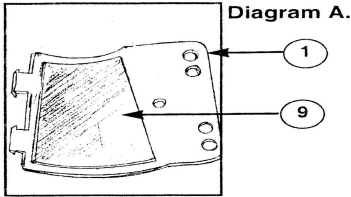

1. Install die cut Rubber Clamp Spacers to each clamp half. Diagram A.

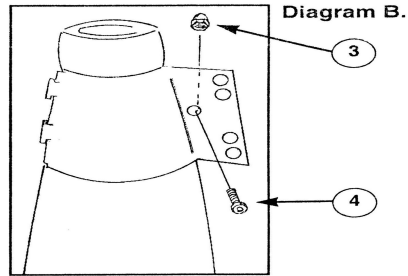

2. Put Clamps on fork.
 A. Must hit upper triple clamp.
 B. Use M6 x 12 Screw and Acorn nut to clamp together. Tighten to 10 ft. lbs.
 Diagram B.

Note: 2a. instruction is for installation of National Cycle Chrome Lower (optional.)

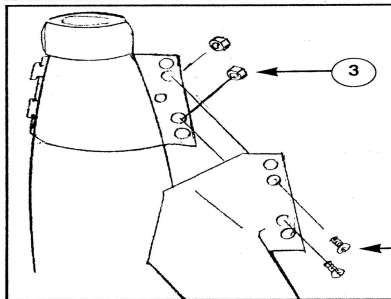

2a. Instruction for Chrome Lower installation.
 A. Use the M6 x 12 Screws and Acorn Nuts thru the two inner holes. Tighten to 10ft. lbs.

Installation of Windshield

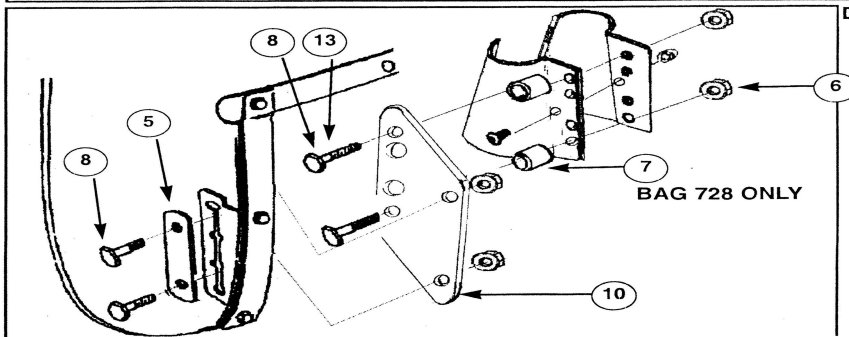

3. Install windshield onto brackets using chrome spacers and flat plate, as shown in diagram C. Spacers are required with installation of KIT JD only.

Make Final Adjustments. Check Clearance.

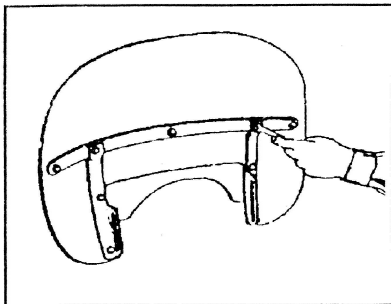

Diagram D.

4. Make final adjustments. Check symmetry of left and right sides and clearance. Gently turn handlebar left and right to full fork lock to assure that no interference occurs between the Hardware, turnsignals or Chrome Lower and the gas tank. **Fully tighten** socket head screws, bolts, and cap nuts.
Optional adjustment of the window. For Heavy Duty™ Windshields only.
 The adjustable window is easily adjusted or changed in all National Cycle Heavy Duty Windshields. Loosen the 6 cap nuts on the vertical chrome strips. Replace or adjust the window. Tighten cap nuts to 2 - 4 ft. lbs. (2.7 - 5.4 Nm), torque pressure.

Warning - Caution - Maintenance

WARNING: National Cycle windshields and fairings are designed to provide wind protection and increased riding comfort, but not protection in the event of a collision with another vehicle, the road, birds, or any other object.

Our products utilize certain features, patented and otherwise, that may minimize injury in certain accidents, but the possibility of injury exists if the screen is broken or if impacted by an object. Always wear eye protection, helmets and protective clothing. Never ride your motorcycle while under the influence of drugs or alcohol.

All of our products are made in conformance and exceed the requirements of D.O.T. SS205,Z26.1, classifications AS6 and AS7, which covers all safety glazing for motorcycle application. Never ride your motorcycle with loose windshield mounting hardware. Check the hardware for tightness regularly.

Today's motorcycles are built with enough frame rigidity to withstand the moderate loads imposed on them by the foreseeable addition of a fork mounted windshield. If the addition of an accessory(ies) adversely affects your motorcycle's stability, immediately remove the accessory(ies). Do not ride a motorcycle that exhibits unsafe handling traits.

Have experienced service personnel correct any problem before riding with the accessory(ies) installed. For further questions concerning handling problems associated with an accessory(ies), contact your dealer, motorcycle manufacturer, or accessory manufacturer.

MAINTENANCE: To clean the screen, wash with a clean soft cloth, plenty of warm water and, if necessary, a non-abrasive soap such as dish washing liquid. Flannel or soft chamois make good cleaning cloths. Paint, glue residue or grease removal: Moisten cotton with Naphtha or Turpentine followed by a wash as above. Apply a high quality plastic cleaner, such as McGuiar's Mirror-Glaze MG-17 or Novus #2, to the screen. This will leave a protective coating in the screen making future cleanings easier. Do not clean polycarbonate in hot sun or high temperatures.

Do not clean the screen with glass cleaners. Do not use rain protective products on the screen. The solvent action of the alcohol in these products will destroy the screen. Do not allow brake fluid, alcohol, or strong solvents to contact the screen or penetrate between the chrome brackets and the Permanent damage will result! To remove fine scratches, use a very soft clean cloth and a fine grade buffing compound. Jewelers rouge or McGuiar's Mirror-Glaze MG-10 are best for this type of buffing. We recommend hand buffing.

STORAGE: Do not use low quality vinyl covers or old shower curtains to store your motorcycle or windshield. These products damage the plastic of windshields and the motorcycle body.

PARTS LIST FOR KITS JC and JD

CHROME HARDWARE KIT	BAG # 720	BAG # 727	BAG # 728										
JC	1	1											
JD	1		1										

Index No. Part No. Description Qty.

Bag 720

1	37-370030	Clamp Taper with Tabs	2
2	37-370031	Clamp Taper with Slots	2
3	42-483002	Acorn Hex Nut	6
4	51-516312	Screw, Button M6x 12	6

Bag 727

5	37-410504	Flat Bracket	2
6	42-433030	Whizlok Nut M8-1.25	8
10	37-372206	Offset Bracket Chrome	2
8	51-516416	Screw, Button M8x 16 x 1.25	8
9	75-764701	Rubber Spacer	4

Bag 728

5	37-410504	Flat Bracket	2
6	42-433030	Whizlok Nut M8-1.25	8
7	49-495535	Spacer, Chrome 1.18 Long	4
10	37-372206	Offset Bracket Chrome	2
8	51-516416	Screw, Button M8 x 16 x1.25	4
9	75-764701	Rubber Spacer	4
13	51-516410	Screw, Button M8 x 45 x1.25	4

INSTALLING MECHANICS: Pass instruction manual onto customer. This contains vital information about the use, adjustments, and maintenance of the product. It also contains important cautionary and warning information. Please take the time to become familiar with your chrome hardware kit and HEAVY DUTY™ or DAKOTA™ WINDSHIELD to obtain the best results in use.

Take precaution against paint damage while installing your windshield kit to your motorcycle. Place a heavy cloth over the front fender of your motorcycle to prevent any scratches or dents from occurring should a tool or part fall during installation.



Hex Key, 5/32"
Two 7/16" Wrenches
and a Phillips screw driver to adjust window if desired.

HEAVY DUTY WINDSHIELDS; TOURING, CHOPPED AND BEADED

ADJUSTING AND CHANGING WINDOWS

The adjustable window is easily adjusted or changed in all National Cycle Heavy Duty windshields.

Loosen the 6 cap nuts on the vertical chrome strips.
Replace or adjust window. Tighten cap nuts to 2-3 ft. lbs (2.7- 5.4 Nm), tightening torque.

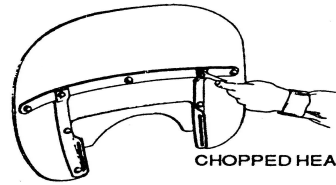

CHOPPED HEAVY DUTY PICTURED

NATIONAL CYCLE ADJUSTABLE WINDOWS ARE AVAILABLE IN 3 STYLES

Red, (FLST, FX type)
WINDOW

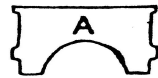

23020 Clear
23021 Red
23022 Blue
23023 Black

FLH NOTCHED



23010 Clear
23011 Red
23012 Blue
23013 Black

FLHS WINDOW



23030 Clear
23031 Red
23032 Blue
23033 Black

SPECIAL INSTRUCTION WHEN MOUNTING TO FLHS

Due to the additional width of the FLHS, it is required to use the frame bracket from the OE windshield. Remove the frame brackets from the National Cycle Heavy Duty windshield. Install OE frame bracket. Note, the bend of the bracket will be to the outside of the windshield.

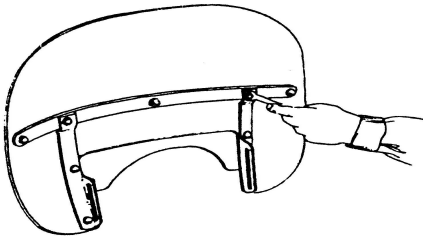

REMOVE FRAME BRACKET SUPPLIED WITH WINDSHIELD

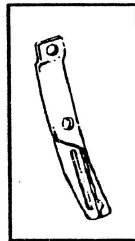

FRAME BRACKET

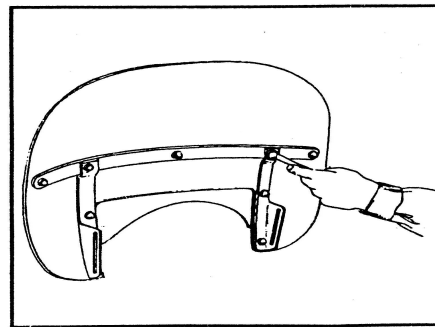

REPLACE WITH OEM WINDSHIELD FRAME BRACKET

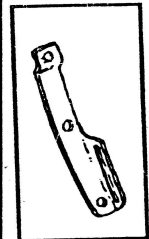

OUTSIDE BEND FRAME BRACKET

TRIMMING: All National Cycle accessory and replacement windscreens are top Quality wind protection devices. Proper care can help these windscreens give many years of motorcycling enjoyment.

Because each rider has their own combination of physical height and/or motorcycle accessories, trimming may become necessary for the best installation. National Cycle Heavy Duty products are made from polycarbonate and can be trimmed if a few simple procedures are followed. I'm sorry, we cannot be responsible for damage to the product which occurs during trimming.

NOTE: Use of jig saw or sabre saw is not recommended!

If the windscreen is to be shortened from the top, remember to choose the new height while seated on the motorcycle (both wheels on the ground), with it normally loaded. In all cases you should be able to see over the top of the screen at least by stretching, in case the screen should become opaque because of rain or dirt.

Too much should not be taken off the top as this will affect how far the air shoots off the top of the screen. The rake angle of the screen, which is adjustable in most applications, will also affect how the air comes off the screen.

Mark the line to be cut with a crayon or china marker; these can be easily washed off. A ruler or piece of paper can be used as a guide to duplicate the original shape.

Secure the windshield by gripping it with your knees. This leaves both hands free for filing or sanding.

The trimming should be done by sanding or filing with a coarse 60-80 grit file. Since shudders, jolts, and sudden shocks can promote cracking, a smooth continuous motion should be used. A flat belt sander will remove material quickly, but keep the sander moving back and forth for a smooth edge.

If a large amount of trimming is required, a band saw can be used safely. Protect the screen with masking tape before cutting. The blade should have about ten teeth per inch. A hack saw will also work well; be careful not to let it bind in the cut.

Once the desired shape is found use the coarse file or sandpaper to round the edges. Any scratches that result from handling can be removed. Refer to the Maintenance instructions.