

LOW-PROFILE REAR TOURING SUSPENSION KIT

General

This kit fits 1997 and later Touring model motorcycles. This kit requires the separate purchase of air pump part number 54630-03A.

WARNING

Installation of any accessory suspension components may affect cornering clearance. This could distract the rider, causing loss of control and could result in death or serious injury.

WARNING

The rider's safety depends on the correct installation of this kit. Follow the procedures listed in this Instruction Sheet and applicable Service Manual. If any procedures are not within your capabilities, or you do not have the correct tools, have your dealer perform the installation. Improper installation could result in death or serious injury.

NOTE

A Service Manual for your vehicle is available from any dealer.

Installation

1. Refer to the Service Manual and follow the instructions given to remove the seat and disconnect the battery cables, negative cable first.
2. Raise the rear end of the motorcycle so that the rear wheel is just off the ground. Support the motorcycle with suitable blocking under the frame.

NOTE

Retain the original fasteners for installation of new shocks.

3. Remove the saddlebags from the motorcycle. See the Touring model's Owner's Manual for saddlebag removal.
4. Fasten the air pump, part number 54630-03A to the rear air-suspension adjustment valve on the motorcycle. See the Touring model's owner's manual for valve location. Add 3-5 psi to clear the line but do **NOT** exceed 50 psi.
5. Using the pressure-relief valve located below the gauge on the pump, release the air pressure from the rear suspension.

CAUTION

Failure to relieve air pressure from the rear suspension could cause injury during shock-absorber removal.

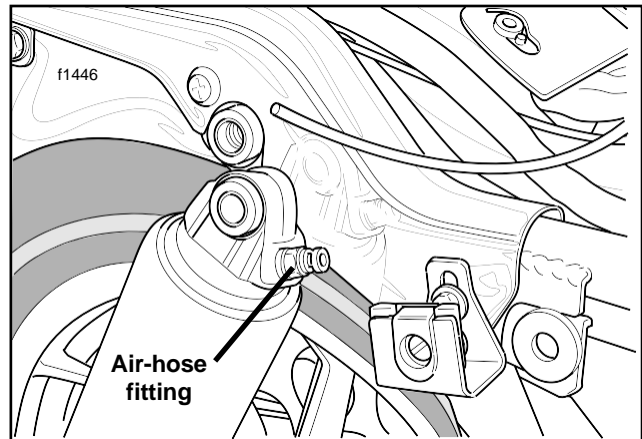

Figure 1. Rear Shock Absorber

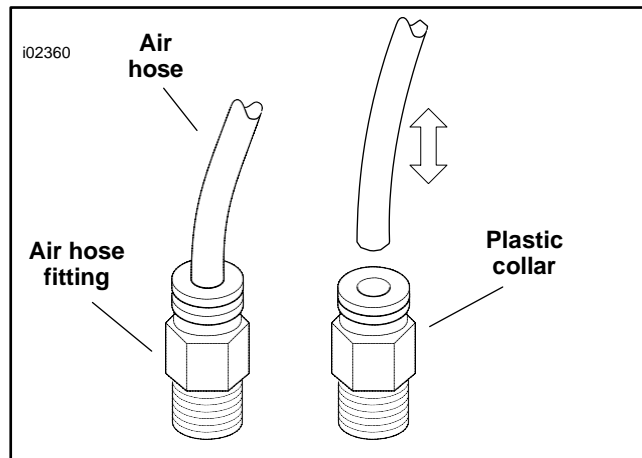

Figure 2. Air Hose Removal and Installation

WARNING

Use caution when bleeding air from the suspension. Moisture combined with lubricant may leak on to the rear wheel, tire, and/or brake components and adversely affect traction, which could result in death or serious injury.

6. See Figure 1 and Figure 2. Remove the air hoses from the shock absorber air-hose fittings.

NOTE

Press the plastic collar down on the air-hose fitting to remove and install the air hose.

7. Remove the air hose fittings from the shock absorbers. Save the fittings for installation on the new shocks.

NOTE

Air-suspension shock absorbers are oil filled and must be kept upright at all times to prevent oil leakage.

8. Remove the lower mounting bolts and washers from the shock absorbers.

9. Remove the upper mounting bolts and washers from the shock absorbers.
10. Apply teflon tape or thread sealant to the air-hose fittings removed in step 7.
11. Replace the plugs in the new shock absorbers with the air-hose fittings removed in step 7. Tighten the fittings until they are snug in the shock absorbers.
12. Install the plugs removed from new shocks (in Step 11) into old shocks to prevent oil loss.
13. Install the washers removed in step 9 onto the upper shock bolts and push the bolts through the shock upper bushings. Apply two or three drops of Loctite 243 (blue) to the exposed threads of the upper shock-mounting bolt.
14. Fasten the top of the new shocks to the frame. Tighten the upper shock bolts to 33 – 35 ft-lbs (45 – 47 Nm).
15. Install the washers removed in step 8 onto the lower shock bolts and push the bolts through the shock lower bushings. Apply two or three drops of Loctite® 243 (blue) to the exposed threads of the lower shock-mounting bolt.
16. Fasten the bottom of the new shocks to the swingarm. Tighten the lower shock bolts to 35 – 40 ft-lbs (47 – 54 Nm).
17. Fasten the air hoses, removed in step 6, to the air-hose fittings on the new shocks.

CAUTION

Do not exceed maximum air pressure of 50 psi for low profile rear suspension. Air components fill rapidly. Therefore, use low air line pressure. Failure to do so may result in possible damage to components.

18. Fasten the shock-absorber air pump to the rear air-suspension adjustment valve. Pressurize the rear air-suspension system to check for air leaks. Adjust air pressure for rider comfort and to accommodate changing load conditions. Do **not** exceed 50 psi.
19. Install the saddlebags.
20. Reconnect negative(-) cable to battery.

WARNING

After installing seat, pull upward on front of seat to be sure it is in locked position. While riding, a loose seat can shift causing loss of control, which could result in death or serious injury.

The following are recommended Starting points; adjust to suit load conditions, riding style and comfort desired.

NOTE

Less initial pressure does not necessarily result in a softer ride.

Recommended Pressures-Kit 54631-02B
Shock Loading Recommended Pressures

	PSI	kPa
Single rider under 160 lbs.	0-5	0-34.4
Single rider 160-200 lbs.	0-10	0-68.8
Single rider over 200 lbs.	5-10	34.4-68.8
Two-up 180 lb rider and 120-150 lb passenger	20-30	137.6-206.4
Two-up 180 lb rider and 160 lb passenger	25-35	172-240.8
Two-up and Fully loaded Bags	40-50	275.2-344
Maximum Pressure	50	344

Item	Description	Part No.
1	Low-Profile Shock Absorber	54661-02A